

Owner's Manual

Copyright 1995-1998

Manual Part # 890015

Rev.5D

1/5/98

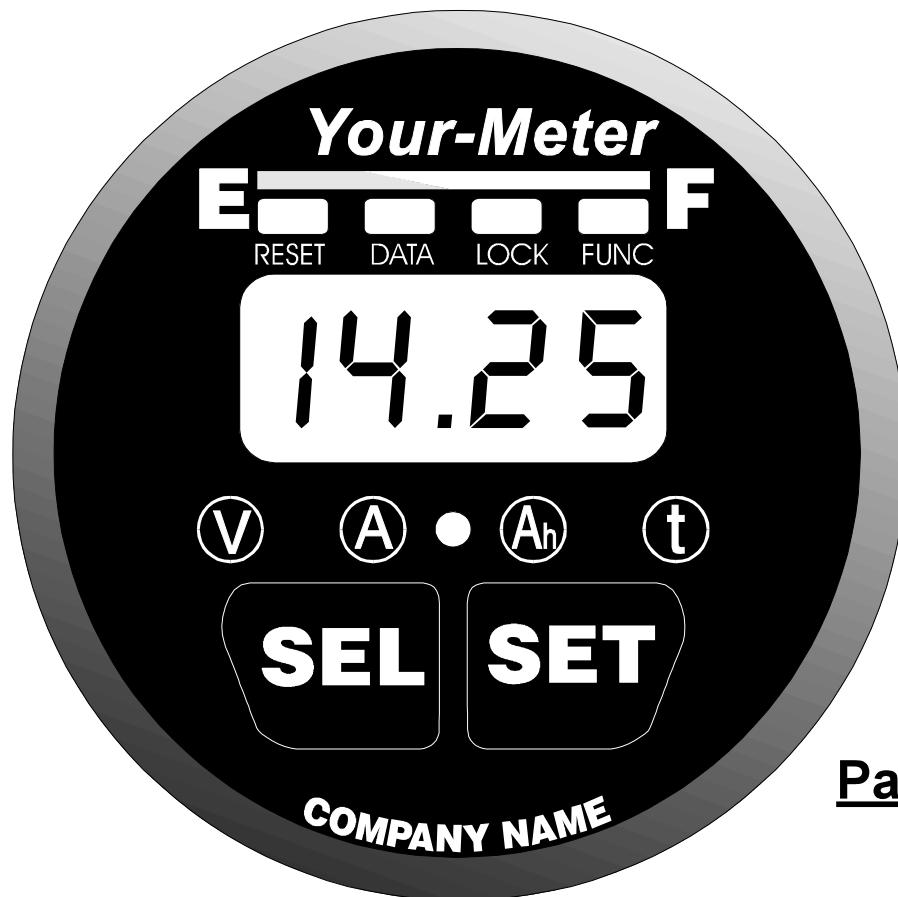

Patented

Graphic and Digital Displays!

The *Ultimate* battery monitor for...

...Marine Systems

...Alternative Energy Systems

...Recreational Vehicle Systems



...Industrial Lift Truck Applications

...Electric Vehicles and many more!

**The world's most accurate
state-of-charge monitor!**

Help Index

DO NOT INSTALL OR USE THIS PRODUCT UNTIL YOU HAVE READ THE ENTIRE OWNER'S MANUAL. IMPROPER INSTALLATION OF THIS UNIT MAY BE HAZARDOUS AND VOIDS YOUR WARRANTY.

- Advanced Functions, 30-38
- Battery Basics, 8
- CE** Declaration of Conformity, 51
- Charge Efficiency Factor, 23
- Charged Parameters, 22-23
- High Voltage Notes, 50
- Historical Data, 29
- Installation (General), 9-15
- Introduction, 7
- Low Battery Alarm, 27, 35-38
- Low Voltage, 27
- Meter Wiring Detail, 14
- Mounting, 10
- Operation (Basic), 18-24
- Options and Versions, 44
- Peukert's Equation, 26, 39-42
- Prescaler (optional), 45
- Quick Reference Guide, 5-6
- Reading the Bar Graph, 19
- Removing, 11
- Reset and Lock, 28
- Serial Port, RS-232(optional), 49
- Setting Battery Capacity, 21
- Setting Peukert's Exponent, 26
- Setting Up , 24
- Shunt & Battery Wires, 13
- Specifications, 3
- Start Up, 16
- Synchronizing Your Meter, 17
- Temp. Sensor (optional), 25
- Troubleshooting, 43
- Using the   Buttons, 20
- Warranty Support, 52
- Wire by Wire Check, 15
- Wiring Overview, 12

Specifications

Voltage: For 12V - 24V systems. **Optional Prescalers extend voltage range.**

- Ⓥ **Standard Model:** Two Auto-ranges: 0 to 19.95V (0.05V resolution)
20.0 to 50.0V (0.1V resolution)
Optional Prescalers: 0-100V, 0-500V (Used with standard model)

Amperage:

- Ⓐ **Low Range:** $\pm 0 - 40.0$ Amps (0.1 Amp resolution)
High Range: ± 500 Amps (1 Amp resolution)

Amp-hours:

- Ⓐh **Low Range:** $\pm 0 - 199.9$ Amp-hours (0.1 Amp-hour resolution)
High Range: $\pm 200 - 1999$ Amp-hours (1 Amp-hour resolution)

Time Remaining:

- Ⓣ **Low Range:** 0 to 199.9 Hours (0.1 hour resolution)
High Range: 0 to 255 Hours (1.0 hour resolution)

Power Requirements:

9.5-40 Volts DC

Current: 50-150 mA (Depends on Ambient light. Display Auto Dims.)
28 mA (Sleep Mode - Bar Graph Display Only)

Shunt type required: 50 mV @ 500 Amp

Accuracy:

Voltage: $\pm (0.6\% \text{ of reading} + 1 \text{ least count of resolution})$
Amperage: $\pm (0.8\% \text{ of reading} + 1 \text{ least count of resolution})$
Amp-hours: Ahr Error $\simeq (\text{Time of measurement} \times \text{current error})$

Physical:

Max. Outer Bezel Diameter: 2.5 inches (63.5mm)

Max. Barrel diameter: 1.95" (50mm)

Max. Depth: (from back of bezel) 3.15 inches (80mm)

Hole Cutout Size: Use 2" or 2 1/16" hole saw (52mm)

Water Resistance: Splashproof front panel.

Weight: 8 Ounces (227g)

Basic Wiring Diagram

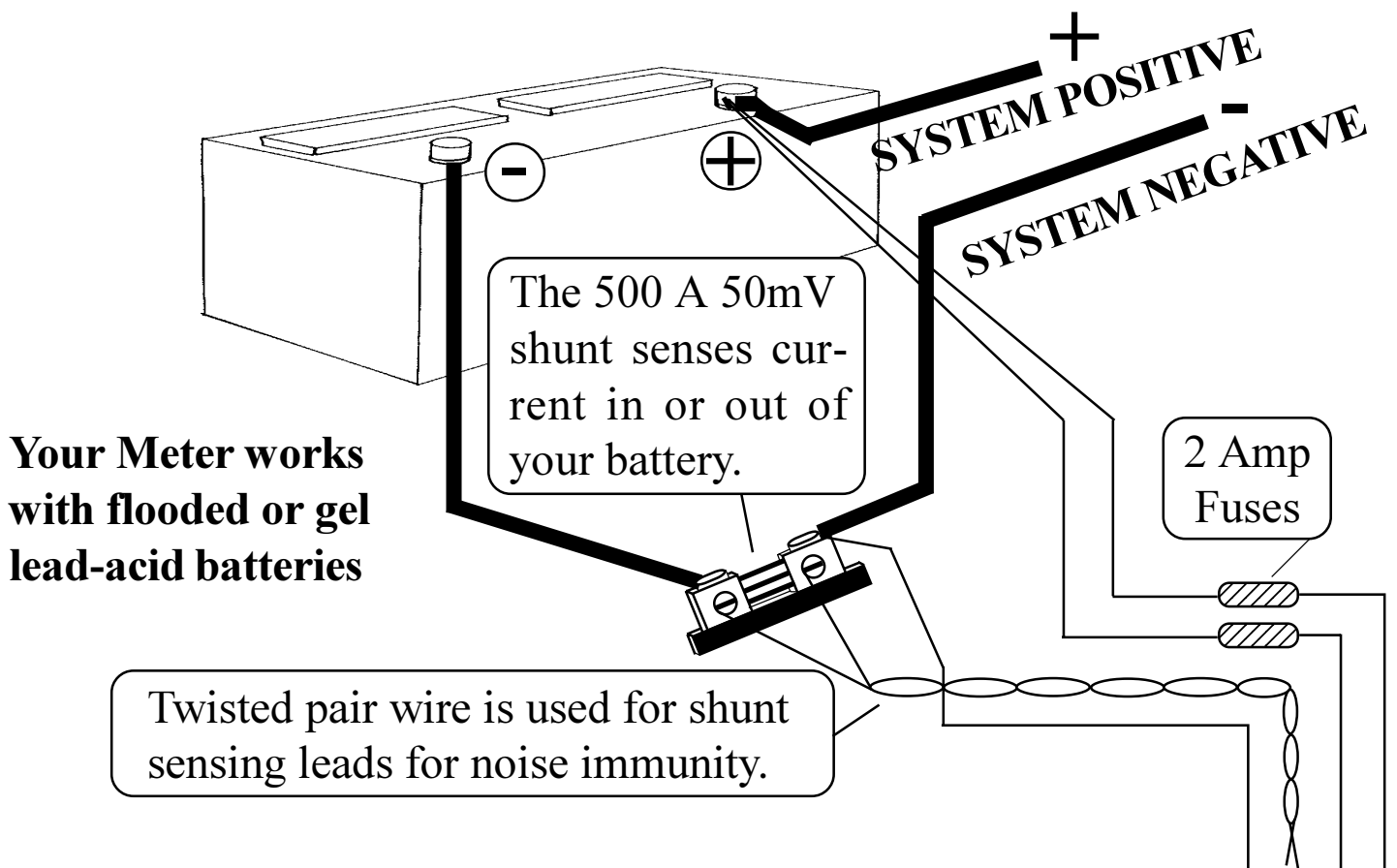

Battery Compartment

Meter Location

Top Rear View of Meter

- | | |
|--|-----|
| -DC Meter Negative (BLACK) | [1] |
| Shunt Sense Lead Load Side (GREEN) | [2] |
| Shunt Sense Lead Battery Side (ORANGE) | [3] |
| Battery Volt Sense (0-50V DC ¹) (BLUE) | [4] |
| +DC Meter Power (9.5-40V DC) (RED) | [5] |
| Optional Temperature Sensor Input | [6] |
| Optional Low Battery Alarm | [7] |
| Optional Temperature Sensor Ground | [8] |

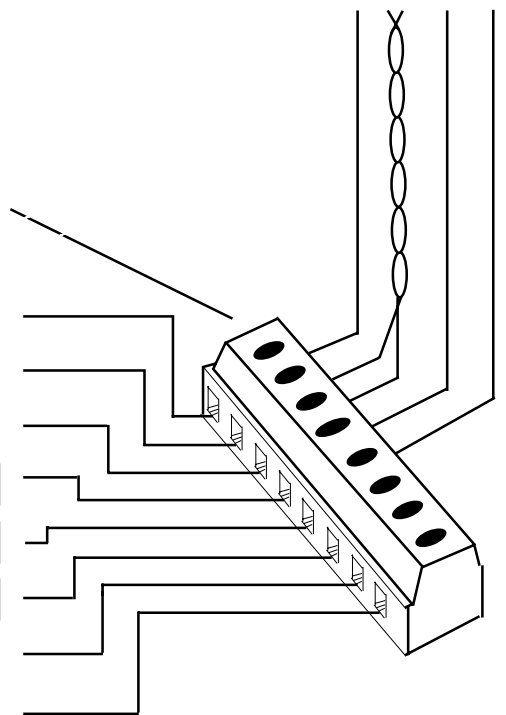

Quick Reference

The Light Bar

The light bar shows state-of-charge at a glance.

Here's what the lights mean:

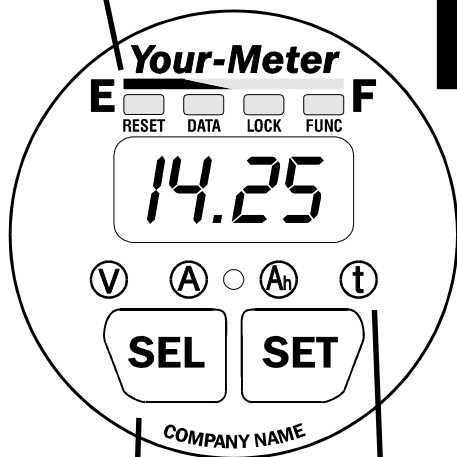

	EMPTY			FULL	
E	GREEN	GREEN	GREEN	FLASH GREEN	F Full
	GREEN	GREEN	GREEN	GREEN	80-99% +
	GREEN	GREEN	GREEN		60-79%+
	YELLOW	YELLOW			40-59%+
	RED				20-39%+
	FLASH RED				0-19%+

Status Lights

Shows what number is being displayed

The **SEL** Button

When you press the **SEL** button, you **SEL**ect a numeric display. In normal operation, each press illuminates a status light. The **V** light indicates Volts are being displayed, the **A** light indicates Amps, **Ah** indicates Amp-hours, and **t** indicates Time. We'll explain these terms on the next page.

For shortest charging times, lead acid battery in marine or RV service is normally discharged 50% then recharged to 85-90% of full. Restoring the last 10-15% of a full charge requires a long time - typically 2 - 3 hours. This means only 35-40% of your battery capacity is actually available for normal use. Occasionally discharging a battery more deeply is perfectly acceptable.

Quick Reference

Amps **(A)**

Amps is the present *flow* of current in or out of your battery. For example, a refrigerator may draw 6.2 Amps of current. This is displayed as **-06.2** (6.2 Amps are being *consumed*).

Amp-hours **(Ah)**

Amp-hours consumed represents the *amount of energy removed* from the battery. If you run a 10 Amp load for one hour, Your Meter will show **-10.0** in the display.

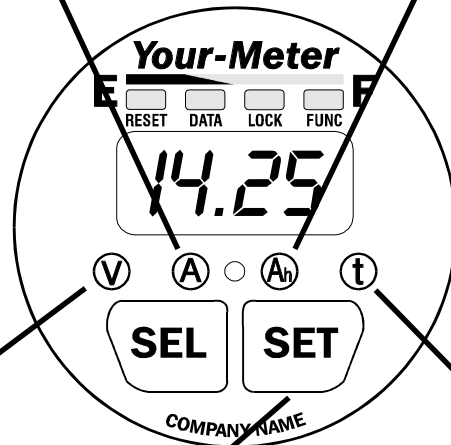

Volts **(V)**

Volts is electricity's *potential to do work*. Voltage helps assess approximate state-of-charge and to check for proper charging. A 12V battery is considered 100% discharged when it drops below 10.5V.

Time **(t)**

Time is an estimate of how long your battery will sustain a load. A Time display of 3.7 hours means you have approximately 3 hours 42 minutes of operating time remaining.

Advanced Functions

Press and hold the **SET** button for 3 seconds to enter the Set Up and Advanced Functions mode. **SEL** appears in the display.

Set Up Features

RESET	DATA	LOCK	FUNC
		Locks front panel.	
	Shows charging efficiency and historical data.		
Resets Amp-hours (AH) or (ALL) defaults.			

Advanced Functions:

Customizes Your Meter's functions. For details read pages 29-30 and pages 34-37.

Key Advanced Functions

RESET	DATA	LOCK	FUNC
-------	------	------	------

- F01** Scanning
- F02** Sleep Mode
- F09** Discharge Floor
- F15** S/W Version
- F17** Test Lights

Introduction

Congratulations! Your Meter is the most advanced (Patents Pending) DC power measurement instrument available. It shows you:

Battery State-of-Charge on a multicolor light bar.

System voltage accurate to 1/20th of a Volt ($\leq 20\text{VDC}$).

System current accurate to 1/10th of an Amp ($\leq 40\text{ Amps}$).

Amp-hours removed from, or put into, your battery.

Time of operation remaining until recharging is required.

This meter is sold under a variety of brand names: Cruising Equipment Company meters are called an **E-Meter**. Heart Interface units are labeled **Link 10**. Other companies have private brand names for this product. For convenience, this manual refers to all units as "**Your Meter**" since all meters support identical functions.

For installation and operation questions, please contact the company whose name appears on the face of **Your Meter**. For warranty and technical support please follow the process outlined on Page 51.

If you wish Your Meter to support an external Low Battery Alarm, such as a bell or buzzer, or if you need Your Meter to report data to a computer or data logging unit, these options must be included at the time of manufacture and can not be retrofitted in the field.

The installation of Your Meter is simple, as is its operation. However, there many advanced features and functions, so please take the time to read and thorough understand this manual.

Installers Note: This manual contains operating instructions. Please leave it with the meter!

Battery Basics

Why monitor a battery?

Batteries can be ruined by excessive discharge. They may also be damaged by under-charging. A battery (or bank of batteries) may be storing less energy than you think. Your Meter provides all the key data you, or your technician, need to make decisions about battery use and charging.

How does Your Meter work?

Your Meter uses sophisticated microprocessor technology to report all significant battery information. Your Meter monitors battery voltage and current over time to report Amp-hours consumed and time remaining -- precisely the information necessary to maximize system performance.

What's an Amp-hour?

Batteries are rated by Amp-hour capacity. A battery which delivers one Amp for one hour has delivered one Amp-hour. Marine and RV deep cycle battery capacity is based on their 20 hour discharge rate. A battery which delivers 10 Amps to a load for 20 hours before battery voltage drops to 10.5 Volts, is considered a "200 Amp-hour" battery. 10 Amps times 20 hours equals 200 Amp-hours.

For maximum life you should never discharge more than half the rated capacity of a battery. Therefore, if you have a 200 Amp-hour battery, you should recharge when Your Meter shows -100 in the Amp-hour display. The -100 means 100 Amp-hours have been *removed* from your battery.

**FOR MAXIMUM BATTERY LIFE, RECHARGE
YOUR BATTERIES WHEN YOU HAVE DIS-
CHARGED 50% OF THEIR AMP-HOUR CAPACITY.**

Installation

Basic installation of Your Meter on a 12 or 24 Volt system involves only 5 wires. Because Your Meter will work on systems up to 500 Volts, special high voltage installation techniques are discussed beginning on Page 44. You need to read this section if you're working on an electric vehicle or system where more than 50 Volts is encountered. If your installation is on a 12 or 24 Volt system, let's get to work!

Installation Planning

First, gather all the tools you'll need for installation. We recommend:

- * A 2" or 2 1/16" (52mm) hole saw to make the panel cutout.
- * A 3/8" drill with bits to run power and shunt wiring.
- * An adjustable 9/16" wrench for shunt bolt connections.
- * Wire stripper/crimper and a small flat blade screwdriver.

Make sure you have all the parts you'll need to complete the job:

- * A 500A - 50 mV shunt (May be supplied with Your Meter)
- * #18 or #16 *twisted pair* shunt wire long enough to reach from the battery to the meter location. Ask your dealer for Cruising Equipment PN 910009 - 25' 4 twisted pair cable or PN 910010 - 50' 4 twisted pair cable (not included).
- * 2 in-line fuse holders with 2 Amp fuses.

CAUTION: DO NOT INSTALL FUSES UNTIL YOU COMPLETE INSTRUCTIONS ON PAGE 10-15.

- * A short heavy duty battery cable to run from one shunt bolt to the battery. Cable is available at auto and marine shops.
- * Assorted small gauge crimp type terminals for connecting the power, shunt, fuses, and voltage sense leads.

Mounting

Our Patent Pending "Ratchet Ring" makes mounting easy and fast .

TIP: When installing from the front of a panel or dashboard slide the Ratchet Ring onto cable with correct orientation and then connect the wires.

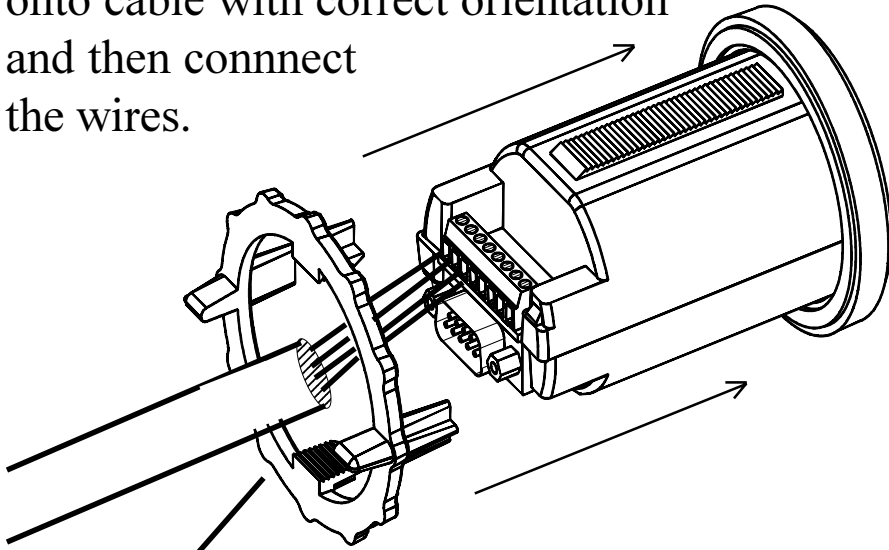

Push Ratchet Ring on until firmly in contact with panel.

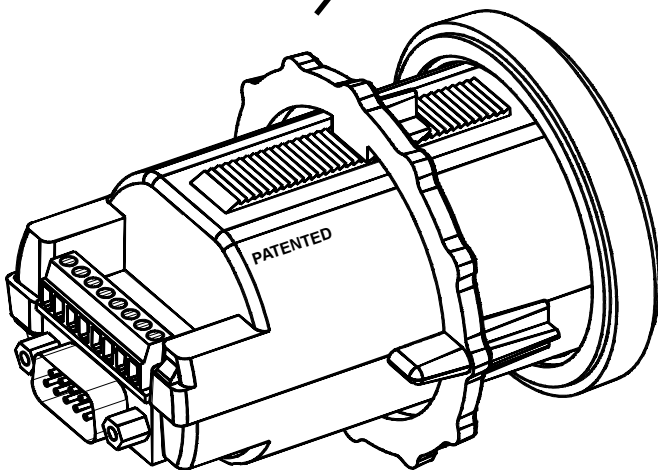

CAUTION!

Orient ring so the ratchet teeth will engage properly. Practice installing and removing ring before final assembly. Considerable force is required, this ensures the ring will not loosen over time.

Install the meter from the front of your panel. The panel thickness may be from 1/16" to 1 1/2". Slip the locking ring on from the rear and press forward until its teeth hold the meter securely in place.

The gasket around the ring of Your Meter should provide an adequate seal against moisture. If a sealant is used be sure it is **silicone** so that the meter may be removed without damage.

Removing

Removing Your Meter is the reverse of mounting with a TWIST as shown in the following diagrams.

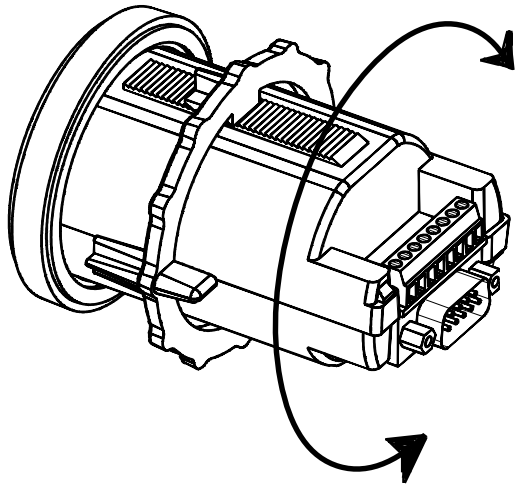

Twist 1/8th turn to unlock teeth.

Then pull lock ring straight back as shown below.

Pull both sides of the lock ring equally

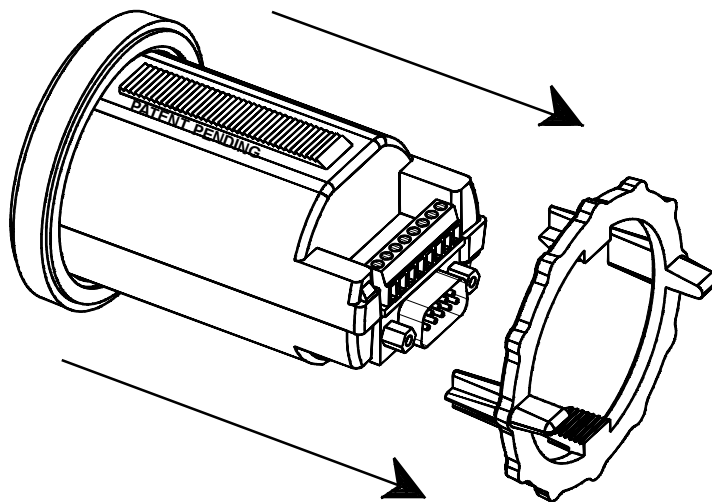

Patented

Wiring Overview

This drawing is for 12V & 24V systems.

For higher voltages see Prescaler use on Page 44.

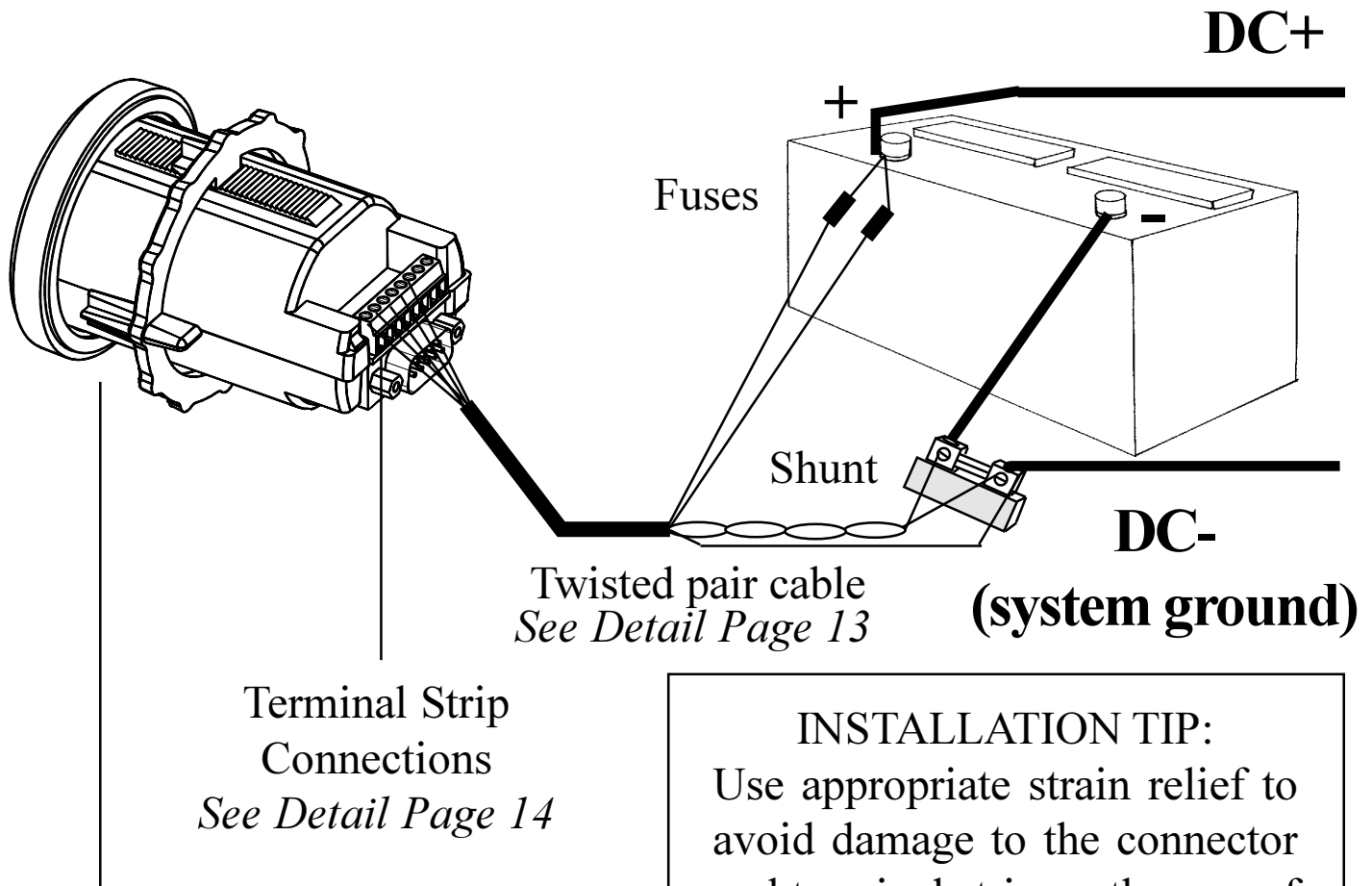

Mounting Page 10

Removing Page 11

TIP: For a neat and professional looking installation use plenty of:

- * Nylon wire wraps
- * Wire wrap anchor points.

NOTE: To limit Voltage measurement error do not exceed wire lengths shown below. Error assumes 16 AWG wire and max. power consumption.

0.5% Error	72 Feet Maximum
1.0% Error	150 Feet Maximum
3.0% Error	450 Feet Maximum

Shunt & Battery Wires

The shunt is the current sensor for Your Meter. Its 500A 50mV rating means that when 500 Amps flows through it there is 50mV generated across it. The millivolt signal is translated into an Amps display in the meter. For example: A 50A load would generate 5mV across the shunt and would be displayed as 50 Amps. **Caution:** In the diagram below, the **darker wires** represent primary wiring and should be able to carry full battery load current. Size appropriately!

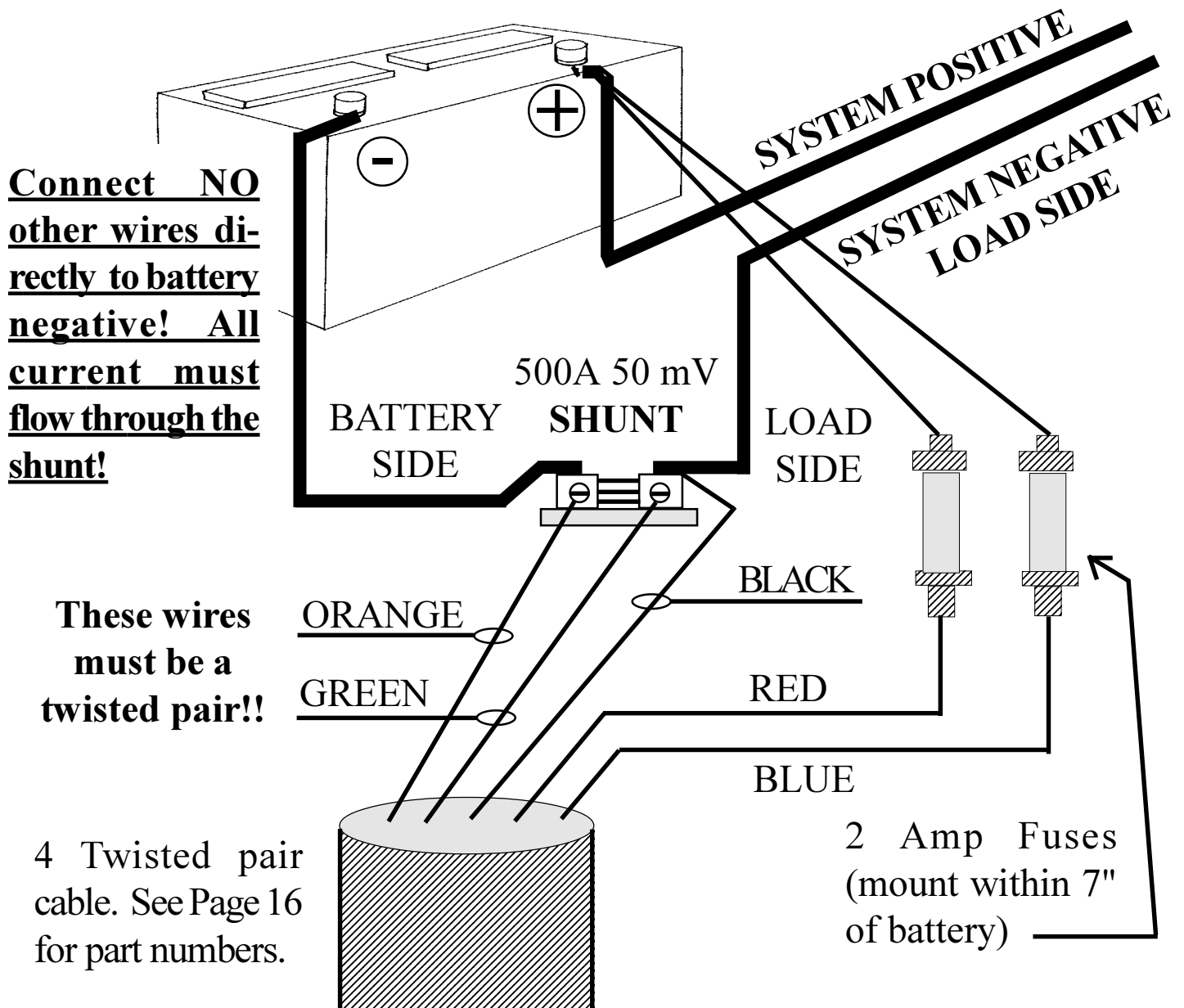

Meter Wiring Detail

Make the necessary wire connections to Your Meter as shown in the following diagram:

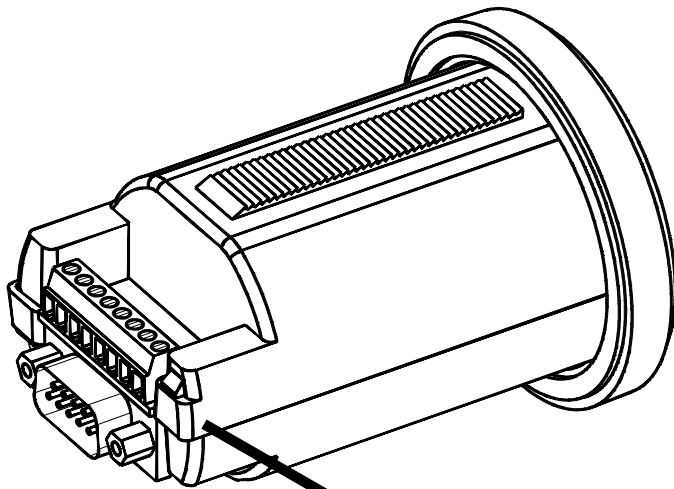

Color code shown for
CECO 4 twisted pair
cable. Part #s below:

PN 910007 -15'
PN 910009 -25'
PN 910010 -50'

CAUTION

Use correct sized screwdriver
for terminal screws. Tighten
firmly but do not over-tighten to
avoid damage

Top Rear View

- | | |
|---|-----|
| DC - Meter Negative (BLACK) | [1] |
| Shunt Sense Lead Load Side (GREEN) | [2] |
| Shunt Sense Lead Battery Side (ORANGE) | [3] |
| Battery Volt Sense (0-50V DC ¹)(BLUE) | [4] |
| DC + Meter Power (9.5-40V DC) (RED) | [5] |
| Optional Temperature Sensor Input | [6] |
| Optional Low Battery Alarm | [7] |
| Optional Temperature Sensor Ground | [8] |

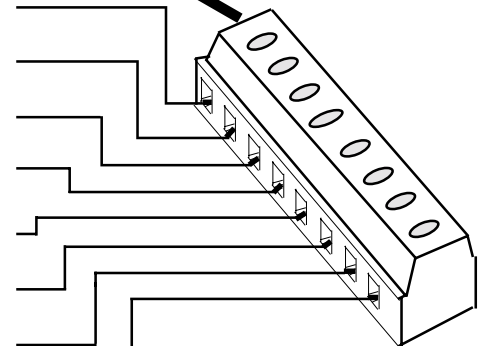

1) For Voltages above 50V a Prescaler must be used. See Page 44.

Wire by Wire Check

Most failures and problems are due to wiring errors. Please double check the wiring. (Color code shown is for CECO wire Part #s on Page 14.)

- # 1 - **DC Power (Black Wire)**. Start at terminal #1 of the meter and follow it to the big bolt on the Load side of the shunt. **Do not connect this wire to the small screw terminal with the Green shunt sense lead.**
- # 2 **Shunt Sense Lead Load Side (Green Wire)**. This wire connects to the small screw on the Load side of the shunt. **This wire must be a twisted pair** with the Orange wire described below. To check this wire start at terminal #2 and follow it to the small screw on the Load side of the shunt. **There should be no other wires connected to this screw.**
NOTE: Also check the primary wiring from the shunt to the battery. There should be only one heavy cable from the Battery side of the shunt to the battery. All loads and sources must be connected on the other side of the shunt. **Only the shunt may be connected directly to battery negative!**
- # 3 **Battery Side of Shunt (Orange Wire)**. **This wire must be a twisted pair** with the Green wire described above. To check this wire start at terminal #3 and follow it to the small screw on the Battery side of the shunt. **There should be no other wires connected to this screw.**
- # 4 **Voltage Sense Wire (Bat.+) (Blue Wire)**. From terminal #4 this wire should run to a 2 amp fuse holder, located within 7" of the battery. The other side of the fuse holder should go to the positive (+) battery post. If Voltage is greater than 50V, see High Voltage Prescaler, Page 44.
- # 5 **+ DC Power (Red Wire)**. This wire should run from terminal #5 to a 2 Amp fuse holder located within 7" of the battery. The fuse should not yet be installed. The other side of the fuse holder goes to the battery. If power supply Voltage is above 24V, see the Electric Vehicles section, Page 45.

Start Up

Once you have completed ALL instructions on Page 17, insert the voltage sense wire fuse, then the meter power fuse. (BLUE wire fuse first, RED wire fuse last!) The fuse should be in a fuse holder and should be connected in a smooth motion. A "ragged" power up may cause a meter lock up. Both the bar graph and digital display should come on.

Factory Default Settings

Your Meter comes on in the **V** (Volts) mode with the display flashing to indicate that it has been powered up from the de-powered state. (see page 26) Left untouched for 10 minutes, Your Meter will go to "sleep", turning off the digital display leaving only the bar graph on. (This is a power saving feature.) Touching either the **SEL** or **SET** buttons will return Your Meter to the function Your Meter was in when it went to "sleep".

Your Meter is designed to work "out of the box". The factory default values are appropriate for a moderate capacity 12V liquid lead acid battery and a typical user display and function setup. **Often the only change that must be made is setting the battery capacity.** You may also have to set the appropriate Peukert's exponent for your battery (See page 24). Special functions and display options are described beginning on Page 27.

Your Meter's factory default settings are:

1. **Automatic Scanning** of V, A, Ahrs, and time will be **OFF**.
2. **Sleep Mode is ON.** Turns digital display off after 10 min.
3. Charge Efficiency Factor (CEF) equals 90% and **learn CEF mode is on.**
4. **Charged Parameters:** Voltage =13.2, Charged Current =2%. The battery must exceed 13.2V and the current must be less, in Amps, than 2% of declared capacity for 5 minutes for Your Meter to consider the battery full.
5. **Battery capacity** set to 200 Amp-hours.
6. **Peukert Exponent** = 1.25.

Synchronizing Your Meter

Synchronize Your Meter to a full battery.

After installing Your Meter, charge the battery until the far right Green LED begins flashing, which indicates the Charged Parameters have been met. Amp-hours will have started at 0 and counted up as a positive number. As you begin discharging the battery, the LED will stop flashing and the numeric Amp-hour display resets to 0. Your Meter is shipped from the factory assuming a 200 Amp-hour battery. Your battery may be a different size. To change battery size, see Page 21.

Staying in Sync, Removing Accumulated Negative Ahrs.

Should Your Meter ever become out of sync with the battery state-of-charge simply charge until the far right LED flashes Green. You may also get back in sync by charging until the battery is full and then resetting the Amp-hours to zero through the **RESET** function.

If Your Meter should accumulate a negative number in the Amp-hour display you will have to charge until you meet the conditions for a recalculation of the Charging Efficiency (CEF) as described on Pages 22 & 23. If you do not meet all five of the conditions listed below you will not get a recalculation of the CEF and a reset to Zero Ahrs consumed.

CONDITIONS TO RESET TO ZERO

- 1) Discharge 10% of declared battery capacity to trigger algorithm
- 2) Recharge until 100% of the Kwhrs removed have been returned.
- 3) The Voltage must be above the Charged Voltage Parameter.
- 4) The current must be below the Charge Current Parameter.
- 5) Conditions 3 & 4 must be met for 5 minutes (1 min. for AE default)

Operation

Although Your Meter is a very sophisticated device, obtaining basic battery information from it is simple. With the unit turned on and the **V** (Volts) LED on, let's learn how to display the four most important DC system parameters .

When you touch the **SEL** button, you are **SEL**ecting the display you wish. Each time you touch **SEL** in normal operation, you will toggle to the next item to the right **V** (Volts) goes to **A** (Amps) to **Ah** (Amp-hours) to **t** (time).

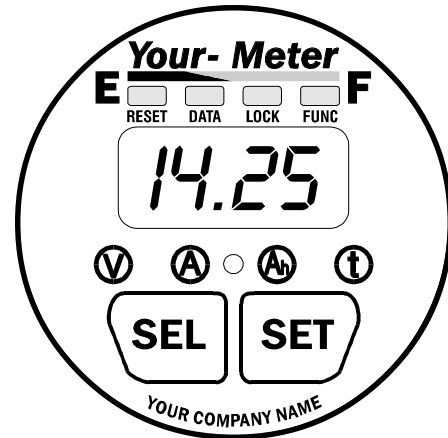

Now press **SEL** to bring up these functions.

- V** **Volts** is the electric *potential to do work*. Voltage is useful to assess the approximate state-of-charge and to check for proper charging. Examples: An at rest, fully charged battery will show about 12.8V. A 12 V battery is 100% discharged when it reaches 10.5Volts with a 20 hr. rated load applied. A typical charging voltage would be 14.2V.
- A** **Amps** is the present *flow* of current in or out of the battery. For example, a refrigerator may draw 6 Amps of current. This is displayed as - 6 . 0 (6 amps are being *consumed*). Discharge is shown as a negative number and charging is shown as a positive number (unsigned).
- Ah** **Amp-hours** consumed represents the *amount of energy removed from* the battery. If you run a 10 Amp load for one hour then ten Amp-hours are consumed. Your Meter will show -10 in the **Ah** display. During charging Your Meter will compensate for charging efficiency and count back up toward 0 .
- t** **Time** is an estimate of how long (in hours) the battery will sustain a load. It is based on a selectable, time averaged, rate of discharge. Default is the average of the last four minutes of use. (See Page 23)

Reading the Bar Graph

Above the digital display are four LEDs. They tell you the battery's state-of-charge at a glance. Four green LEDs means your battery is full. One flashing red light means it's nearly discharged. The table below shows the six different displays indicating battery state-of-charge. Under certain light conditions green may appear yellow.

BATTERY STATE-OF-CHARGE	EMPTY FULL			
	E			F
Full (Charged Parameters Met)	GREEN	GREEN	GREEN	FLASH GREEN
80-99% +	GREEN	GREEN	GREEN	GREEN
60-79%+	GREEN	GREEN	GREEN	
40-59%+	YELLOW	YELLOW		
20-39%+	RED			
0-19%+	FLASH RED			

Under the LED bar graph are the words **RESET**, **DATA**, **LOCK**, and **FUNC**. These words are ignored during normal operation. They are used to indicate programming and advanced function modes which are explained beginning on Page 34.

Setting Battery Capacity is Important

The LED bar graph display shows how much of your battery has been consumed. If you do not set your battery capacity correctly, your bar graph will not give you an accurate indication of battery state-of-charge. Your Meter also uses declared capacity to calculate the Time Remaining, the charged current for Charge Efficiency Factor calculations, and other control functions.

Setting capacity correctly is *very* important, see Page 21

Using the **SEL** **SET** Buttons

Pressing and holding the **SET** button for 3 seconds enters the Set Up and Advanced Functions mode. The word **SEL** appears in the display, prompting you to press the **SEL** button to choose what function you want to **SEL**ect.

Pressing **SEL** chooses a *variable* or *function*. The SET UP mode always begins at the **V** (Volts) function. Each press of the **SEL** button scrolls to the next item. When a variable or function is selected, its LED is on and its present value is displayed. To change an item press the **SET** button until the value appears that you wish. The order displayed and brief descriptions are below.

LIGHT DESCRIPTION

- V** Charged Voltage (The Voltage above which the battery must rise to be full.)
- A** Charged Current % (Charging current must be below this percentage times the battery capacity to be considered full. See Page 22-23.)
- Ah** Battery Capacity in Amp-hours
- t** Time interval over which current is averaged for time remaining function.

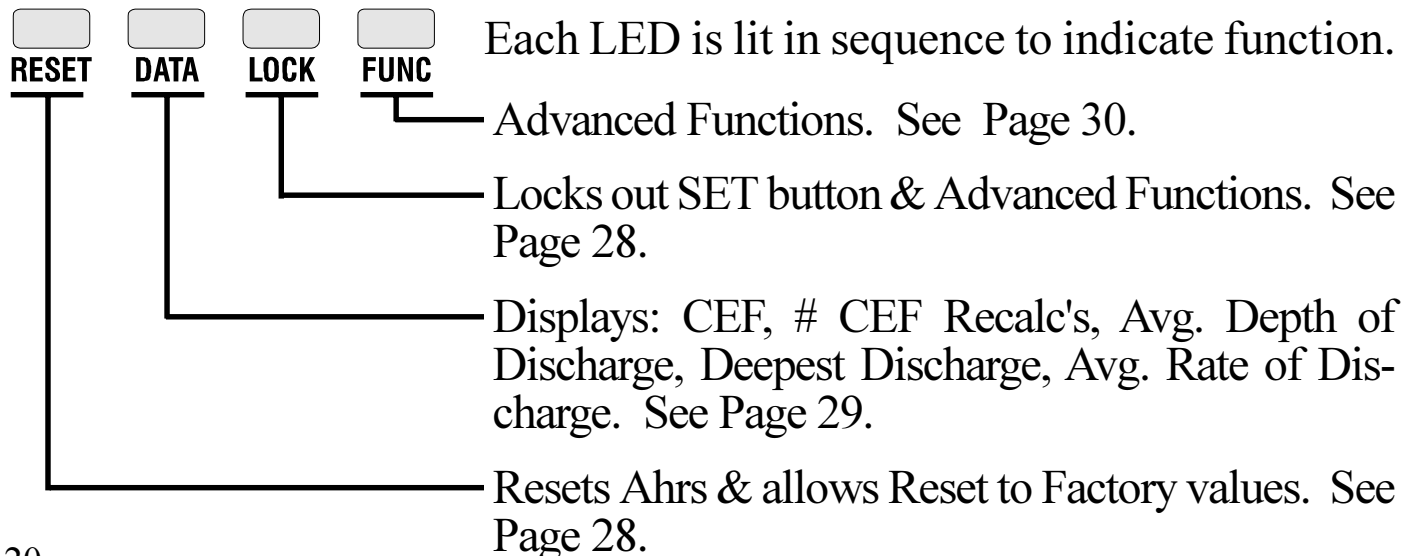

Setting Battery Capacity

The first time you use Your Meter, it assumes you have 200 Amp-hour lead acid batteries. If your battery capacity is different you must change the declared battery capacity. Follow these instructions to declare a new capacity:

- 1) Press and hold the **SET** button for 3 seconds to enter SET UP (and Advanced Functions) menu. **SEL** appears in the display. Press **SEL** and notice that the green **V** LED is on.
- 2) Press **SEL** again and note that the **A** light comes on. Press again and now the **Ah** LED is on and 200 appears in the display. This is the default battery capacity.
- 3) Now press and hold the **SET** button to scroll through battery size options. The display will show 1 Amp-hour increments from 20-40 Amp-hours of capacity, 5 Amp-hour steps from 40-100 Amp-hours capacity and 20 Amp-hour steps over 100 Amp-hours of capacity. If you continue to hold **SET**, after 4 increments the display scrolls faster. When the value you want appears, release the **SET** button. If you overshoot your capacity you will have to scroll all the way to 1980 Ahrs after which the display will roll over and begin scrolling up starting from 10 Amp-hours. NOTE: Versions of Your Meter prior to serial number 05000 increment only in 20 Amp-hour steps from 20 - 1980 Amp-hours .
- 4) After 10 seconds the meter exits the Set Up mode and the selected value is stored as the new battery capacity and the display returns to **V** (Volts).

Tip: All SET UP and ADVANCED FUNCTIONS begin with the **SET** button. SET UP is normally done at installation. The **SET** button may be **LOCKED** to prevent unauthorized personnel from tampering with the **SET** functions. See "LOCK" on Page 32.

The Charged Parameters

Your Meter depends on the Charged Parameters to stay in sync with the battery state-of-charge, to automatically reset to Zero, and to automatically calculate the CEF. The default settings are for 12V lead acid (liquid or gelled) batteries. They have been carefully chosen to work on most systems, including constant voltage and multiple step charging systems.

The factory Charged Parameters are 13.2 Volts and 2% of battery capacity as a charged current. (2% of the default battery capacity of 200 Ahr equals 4 Amps). Several conditions must be met for a recalculation of the CEF and a reset to Zero: First 100% of the energy removed from the battery must be returned, additionally the battery must be above 13.2 Volts and the current must fall below 4 Amps, for five minutes, when all these conditions are met the battery is considered full.

CAUTION: If your battery voltage is other than 12V you MUST set up an appropriate Charged Voltage.

If the charged parameters are not set correctly,

Your Meter will never recalculate the CEF!

Please consider changing only the battery capacity unless your system falls into one of the following categories:

1) Battery chemistry other than lead acid.

12 Volt NiCad (and NiFe) systems would normally use 15.5 to 15.7 as the Charged Voltage. See your battery specifications for guidance. The Charged Current % can probably stay at 2% of declared battery capacity.

2) Charging normally ends before current drops below 2%.

If the charging system is normally shut down before charging current drops below 2%, the Charged Current % will have to be changed.

Charged Parameters & CEF

If you change the Charged Parameters please use the following rules.

- 1) **The Charged Voltage Parameter MUST BE AT LEAST 0.1V BELOW the voltage at which the charging system finishes charging.**

Example: If your charging system finishes the battery at 13.8 Volts, a Charged Voltage Parameter of 14.0 Volts will not work. Lower the Charged Voltage Parameter to 13.7 Volts or less.

- 2) **The Charged Current % times declared Battery Capacity MUST be GREATER than the minimum current at which the charging system maintains the battery, or turns off.**

If the Charged Current % times the Battery Capacity is less than the current at which the charging system switches off, the Charged Current Parameter cannot be met. For example, if the charging system shuts off when the current is 10 Amps, using the factory default value of 4 Amps (2% of 200 AHrs), will not work. Changing the Charged Current % to 6% would give a Charged Current of 12 Amps which would work.

WHY IS THE CEF IMPORTANT: The CEF determines the rate at which the meter counts back up during charging to compensate for the inefficiency of the charging process. The CEF has a factory default value of 90% . This means that you must return 10.0 Ahrs to store 9.0 Ahr in the battery.

If you have a charging system that cannot satisfy the Charged Parameters, the CEF will not be recalculated and the meter will use the default CEF of 90%. This will work fine in most systems. You may notice an accumulation of negative Ahrs. If so, set up appropriate Charged Parameters or resynchronize periodically.

Setting Up

Five different displays are available in the Time function. You may select present consumption level, a four minute average, a sixteen minute, or a 32 minute average, or display the percent of rate compensated capacity remaining. Which method is best for you depends on your installation. Most installations will find four minute averaging appropriate. To SET UP  follow the procedure outlined on Page 20. As you press the **SET** button the following values will appear, use the table below to choose the appropriate averaging period.

Instantaneous:	Time Remaining Set Up Display: 000
4 Minute Average:	Time Remaining Set Up Display: 00I
16 Minute Average:	Time Remaining Set Up Display: 002
32 Minute Average:	Time Remaining Set Up Display: 003
Percent Remaining:	Time Remaining Set Up Display: 04P

Operating Tips: Use the longest period of time you can to insure long term load variations are considered. For instant feedback, use the 000 (no averaging) display. Time is in hours and 1/10th's of hours. In the Percent of Capacity Remaining mode, a full battery is displayed as 100P and counts down as your discharge. The Percent of Battery Capacity Remaining is referenced to the selected discharge floor and uses the instantaneous (not averaged) rate of discharge. The percent of capacity remaining display shows the percent number which drives the Bar Graph. This function is very useful on Electric Vehicles.

CAUTION: Time displays are an *estimate* of how long your battery will sustain a load (to your selected discharge floor; default: 100% discharge). Variations in discharge current, incorrectly set battery capacity, Peukert's exponent, temperature, and prior battery history may affect the accuracy of this estimate. Please use Time displays only as a guide. Use all displays (Volts, Amps, Amp-hours, and Time) to make informed decision about battery state-of-charge. Do not rely on a single value!

(optional) Temperature Sensor

Your Meter may support an optional two wire temperature sensor. The temperature sensor is activated by turning Advanced Function F16 ON.

With F16 ON, F03 shows battery temperature in degrees Celcius. When activated, F03 will continue to display temperature after exiting the Set Up mode until one of the two front panel buttons, **SET** or **SEL** is pressed.

The limits of the temperature sensor are 0 C (32F) to 99 C (210 F). Versions of Your Meter prior to Serial Number 005000 do not support this function.

Introduction to Peukert Exponent

Your Meter shows true Amp-hours consumed in the Amp-hour display. However, the light bar shows how much *of the available* battery has been consumed. In 1897 a scientist named Peukert demonstrated that as you discharge a battery more quickly, it's *effective size temporarily decreases*. A battery is considered fully discharged with it is no longer able to maintain 10.5 Volts under load. As you'll see in the following table showing the effect on a typical liquid cell battery, the faster the discharge rate, the smaller its effective capacity:

<u>Hours to Discharge</u>	<u>Capacity as percent of 20 hr rating</u>
20	100%
10	84%
5	67%
2	56%
1	47%

In other words, a 100 Amp-hour battery, discharged completely in one hour will only supply 47 Amp-hours before dropping below 10.5V!

Peukert Exponent

Peukert's Exponent is a number which describes how battery capacity shrinks as the rate of discharge is increased. Your Meter uses a number between 1.00 and 1.50 to describe how fast a particular battery will "shrink" when a heavy load is connected. A more complete technical discussion of the Peukert Exponent, and typical value tables is included on Pages 48-41.

The key thing you need to know is that the Peukert Exponent set at the factory, 1.25, will be satisfactory for many liquid cell batteries. Gel cell batteries, or liquid cells with atypical plate structures, may require a different Peukert Exponent. To change the Peukert Exponent, proceed as follows:

1) Press and hold the **SET** button for 3 seconds to enter SET UP (and Advanced Functions) menu. **SEL** appears in the display. Press **SEL** and notice that the green **V** LED is on.

2) Press **SEL** again and note that the **A** light comes on. Continue to press the **SEL** button until the letters F8 appear in the display. This will require eighteen presses of the **SEL** button. The right most LED of the bar graph with the legend **FUNC** under it will be lit.

3) Now press and hold the **SET** button. The default value of 1.25 (or the previously programmed value) will appear in the display. The range of values is from 1.0 to 1.50. Holding down the **SET** button will cause the display to increment in 0.01 steps, after 4 increments the display scrolls faster. When the value you want appears, release the **SET** button. If you overshoot your capacity you will have to scroll all the way to 1.50 after which the display will roll over to 1.00 and continue incrementing. You also have to scroll all the way through to declare exponents between 1.00 and 1.25.

4) After 10 seconds the meter exits the Set Up mode and the selected value is stored as the new Peukert's exponent and the display returns to **V** (Volts).

Alarms

Two Types of Alarms

Your Meter is equipped with both a visual *Power Loss* Alarm and a visual *Low Battery* Alarm. It is important that you understand the difference between these functions.

Power Loss Alarm: Shows when power being supplied to Your Meter has dropped to an unsafe level. Certain display features are turned off as meter power drops below internally set levels.

Low Battery Alarm: Shows when the battery being monitored has reached either a predetermined depth of discharge *or* has encountered at least 15 seconds of continuous low voltage below a settable level. The Low Battery Alarm is controlled by functions F10, F11 and F12 in the *Advanced Functions Section*.

Power Loss Alarm & Reset Annunciation

If the Voltage supplying terminal #5 falls too low an automatic shut down occurs. This voltage varies from a low of 7.2V to about 9.2 Volts depending on how fast the voltage drops. When power is restored, the display defaults to the  function and the digital display flashes. Pressing either the **SEL** or **SET** buttons cancels the flashing display. If the meter is in the sleep mode when power loss occurs, the display will flash for ten minutes and then go to sleep if no buttons are pressed. Once asleep the first button press will wake the display in the flashing mode to annunciate the power loss. The second button press will cancel the flashing display.

Reset and Lock

In addition to reporting primary system values, Your Meter is capable of many other front panel functions and will also display important historical battery data. The words below the bar graph display indicate which of these functions you are accessing. To use these functions you must read and understand the following section of this manual.

Resetting Your Meter

RESET Resets Amp-hours to Zero and Resets Your Meter to Factory Values.

To **RESET** the Amp-hour display to Zero, **SElect** the **RESET** function as previously described. The letters **AH** will appear in the display. Press and hold the **SET** button. After 5 seconds the Amp-hour display will be reset to 0 and the letters **ALL** will appear. If you continue to hold down the **SET** for another 5 seconds all variables and functions are reset to the factory defaults.

Front Panel Locking

LOCK Prevents user access to Set Up and Advanced Functions.

To **LOCK** Your Meter, **SElect** the **LOCK** function as previously described. The letters **LOC** will appear in the display, indicating you are in the **LOCK** function. Press **SET** and the letters **off** appear indicating the front panel is not Locked. Press **SET** again and the letters **on** will appear indicating the front panel is locked. Repeating this procedure toggles the lock off and on, the display will report **off** or **on**, indicating Lock off or on.

Historical Data



RESET



DATA



LOCK



FUNC

Key Battery Data Displayed

DATA Key historical battery information is available through this function. Each time the **SEL** button is pressed while in the **DATA** mode the next piece of data is displayed. Select **DATA** as previously described to see **DATA**.

CEF (Displayed as E99): The Charging Efficiency Factor (CEF) is displayed. A display of E99 indicates a 99% CEF. This number sets the rate at which Amp-hours are counted back up during charging. This is an Amp-hour CEF, not Kwhr efficiency. The Default setting is 90%. **NOTE:** If the CEF display has a u in front of it, this means the CEF has been selected by the user. See Advanced Function F06 for details.

#CEF Recalculations (Displayed as +I999): This is the number of times that the battery has been discharged more than 10% and then recharged until the Charged Parameters have been met. May be considered as the number of charge/discharge cycles the battery has experienced.

Deepest Discharge (Displayed as -i999): Shows the deepest discharge in Amp-hours recorded by the meter since its last **RESET** to factory defaults.

Average Discharge (Displayed as i999): The running average of all discharges as an Amp-Hour value since last **RESET** to factory defaults.

Advanced Functions



RESET



DATA



LOCK



FUNC

Advanced Functions

FUNC Allows setup of Advanced Functions.

To access the **FUNC** mode, **SEL**ect the **FUNC** mode as previously described. The letters **F0i** will appear in the display and the **FUNC** LED will be lit indicating you are in the **FUNC** mode. Continue pressing the **SEL** button until the function you wish to setup appears. Now press **SET** until the desired value or mode appears. Repeat this procedure until you have setup all of the desired advanced functions. Whatever functions you have setup will become active when the display reverts to its normal mode.

F01 **AUTO DISPLAY SCANNING**

Automatically scans V, A, Ah, and T. Each value displayed for 4 seconds.
DEFAULT: OFF **RANGE: OFF or ON**

F02 **ENHANCED SLEEP MODES**

DEFAULT: ON **Range: ON, OFF, AU (AUTOMATIC)**

When the Sleep Mode is ON, Your Meter's numeric display turns off after 10 minutes in order to reduce power consumption. Pressing either SET or SEL buttons returns the numeric display to operation.

When the Sleep Mode is OFF, the numeric display stays on at all times. In the special automatic sleep mode (displayed as **AU**), the numerics are on whenever charging or discharging exceeds 1 Amp. When the rate of charge or discharge remains less than 1 Amp for 10 minutes, the numeric display is turned off to conserve power. When asleep, pressing either SET or SEL reactivates the numeric display. The numeric display automatically wakes up when the rate of charge or discharge exceeds 1 Amp. The Automatic Sleep Mode is ideal for Electric Vehicles.

DEFAULT: ON **RANGE: OFF or ON**

Advanced Functions

F03 DISPLAY OR SET BATTERY TEMPERATURE

If there is no external temp sensor and F-16 is OFF (factory default), this function sets ambient battery temperature used to calculate *rate corrected* battery capacity which drives the LED bar graph and the Time remaining display. Feature not available on units with serial numbers prior to 05000.

DEFAULT: 20C **RANGE: 0-40C** **STEP: 1C**

If F16 is ON and an optional external temperature sensor is connected between Pin 6 and Pin 8 (ground), F03 will display temperature (0-99 C). Temperature will continue to be displayed until one of the two front panel buttons is pressed. Active Temperature display is annunciated by the absence of front panel status indicators. If 0 is displayed at normal (≈ 20 C) temperatures, an open temperature probe should be assumed. If >99 is displayed at normal temperatures, a shorted probe should be suspected.

F04 TURN ON KWHR DISPLAY

Kilowatt-hours are displayed in the Ah mode. (Note: The Kwahr display does not take into account Charging Efficiency. As a condition for a recalculation of the CEF and an automatic reset of Amp-hours to zero, 100% of the energy removed from the battery must be returned. The number in the Kwahr display must be zero or positive to allow a recalculation of the CEF and an automatic reset to zero. You may use this function to verify that this condition has been met.)

DEFAULT: OFF **RANGE: OFF or ON**

F05 USE ALTERNATIVE ENERGY (AE) DEFAULTS

Changes time to meet Charged Parameters to 1 minute from normal 5minutes. (Also consider changing Charged Current to 4%)

DEFAULT: OFF **RANGE: OFF or ON**

Advanced Functions

F06 MANUALLY SET CEF (Not Recommended)

Allows manual setup of CEF. Displayed as two digits. Default display A90 indicates automatic CEF recalculation feature active. Returning to A90 from a user CEF turns the automatic CEF feature back on. If a user set up CEF has been selected it will appear as a UXX in the **DATA** mode. See Page 25.

DEFAULT: A90 **RANGE: 65-99** **STEP: 1**

F07 SET TEMPERATURE COEFFICIENT

Compensates for capacity change with temp. ~ 0.5% Cap/°C. This coefficient must be supplied by the battery manufacturer. The default value is typical for lead acid liquid or gelled batteries.

DEFAULT: 0.5 **RANGE: .1-0.9** **STEP: 0.1**

F08 SET PEUKERT EXPONENT

Sets exponent for Peukert's equation. A setting of 1.0 defeats Peukert's calculation. See *Owner's Manual* pages 39-42 for a discussion of Peukert's equation and typical values for various batteries.

F09 SET DISCHARGE FLOOR

Sets the discharge floor used to calculate bar graph status and time of operation remaining functions. The factory default is to calculate time remaining, and bar graph based on a rate corrected discharge of 100% of declared Amp-Hour capacity. In other words, the bar graph will flash red when less than 20% of your rate corrected (Peukert Amp-Hour) capacity remains. Default time remaining is essentially "time till dead battery".

To insure a margin of safety you may wish to set a different discharge floor. You may wish to set 80% or some other discharge floor for your bar graph.

Advanced Functions

CAUTION: If you set the discharge floor high, such as 50%, and continue to discharge well beyond this point, you will notice that the bar graph does not "fill up" until you have charged the battery above the discharge floor. In other words, if you set the discharge floor at 50% and discharge 75%, you must recharge back up to the 50% level before your bar graph and time of operation will again give you meaningful information.

DEFAULT: 100% **RANGE: 50-100%** **Step: 5%**

F10 - F12 SEE LOW BATTERY ALARM SEE PAGES 35-38

F13 SEE HIGH VOLTAGE NOTES SECTION PAGE 50

F14 ENABLE LOW BATTERY ALARM

In versions of Your Meter equipped with the Low Alarm Switch, this function allows the Low Battery Alarm to be disabled.

DEFAULT: OFF **RANGE: ON, OFF**

F15 SOFTWARE REVISION Displays revision of software.

Please note that the software enhancements to Your Meter may not be retrofitted into earlier versions of this product. If Your Meter has serial number 005000 or larger, it will come with software version E1.3 or greater installed. Earlier versions of Your Meter do not support temperature sensing, small Amp-hour increments, separate alarms for meter power and low battery conditions. Early versions display 255 instead of CCC when the battery is being charged.

Advanced Functions

F16 TEMPERATURE SENSOR ON/OFF

This function turns the optional external temperature sensor on or off. This feature is only operable when a temperature sensor has been connected between Pin 6 and Pin 8 of Your Meter.

To fully understand this feature, please refer to F03 on pages 34-35 of this document. Not available prior to Serial Number 005000.

DEFAULT: OFF RANGE: ON, OFF

F17 LIGHT TEST

This function confirms proper operation of Your Meter's front panel display. When the **SET** button is pressed in the F17 mode, the two top left lights on the Light Bar will display Orange/Yellow color, the numeric display will read 188.8 and all four Status Lights will be on. The display returns to normal when the **SET** button is released. Operation of the two top right green lights on the Light Bar is confirmed when power is initially applied to Your Meter.

DEFAULT: OFF RANGE: ON only while F17 is active.

Low Battery Alarm

Units with serial numbers greater than 005000 allow access to an enhanced Low Battery Alarm feature. To activate this feature, change Function **F14** to **ON**. When F14 is ON, Your Meter displays a visual alarm when the monitored battery meets either of two conditions:

- 1) A settable rated compensated (Peukert) Amp-hour depth of discharge is exceeded or,
- 2) Voltage remains below a settable level for 15 seconds or longer.

When operating Your Meter with the visual Low Battery Alarm function ON, three additional software functions are active. Two of these functions, F11 and F12, set the low Amp-hours and low voltage levels which turn the visual alarm ON. Function F10 is the Low Battery Alarm OFF (Recharge) Set Point.

Visual Alarm Indication

There are two levels of visual alarm.

Level 1: The normal display alternates with a blank Bar Graph and **LO** appears in the numeric display.

Level 2: Once the Level 1 alarm display is acknowledged by the operator by pressing either **SET** or **SEL** once, the Level 2 Alarm flashes the Amp-hours function light while dimming the presently displayed function light. In the event Amp-hours are displayed, the Amp-Hours light will go off at 0.5 second intervals. Once the battery alarm feature is activated, a visual alarm display (Level 1 or Level 2) will continue until Amp-hours are above the Low Battery Alarm OFF (Recharge) Set Point (F10) *and* voltage is above the Low Voltage Alarm Threshold F12 for at least 15 seconds.

Alarm Circuit

Special versions of Your Meter close a circuit to ground when either Visual Alarm level is active. This circuit may be used for audible alarms, generator starting, and so forth. Because additional internal circuitry is included, this option may not be retrofitted to Your Meter in the field.

Alarm Functions

Refer to F14 in the Owner's Manual

Functions F10, F11, and F12 define operation of the Visual Low Battery Alarm as follows:

F-11

TURN^S ON Low Battery Alarm at a set % of rate compensated AHrs Discharged

F-10

TURN^S OFF Low Battery Alarm when AHrs are restored

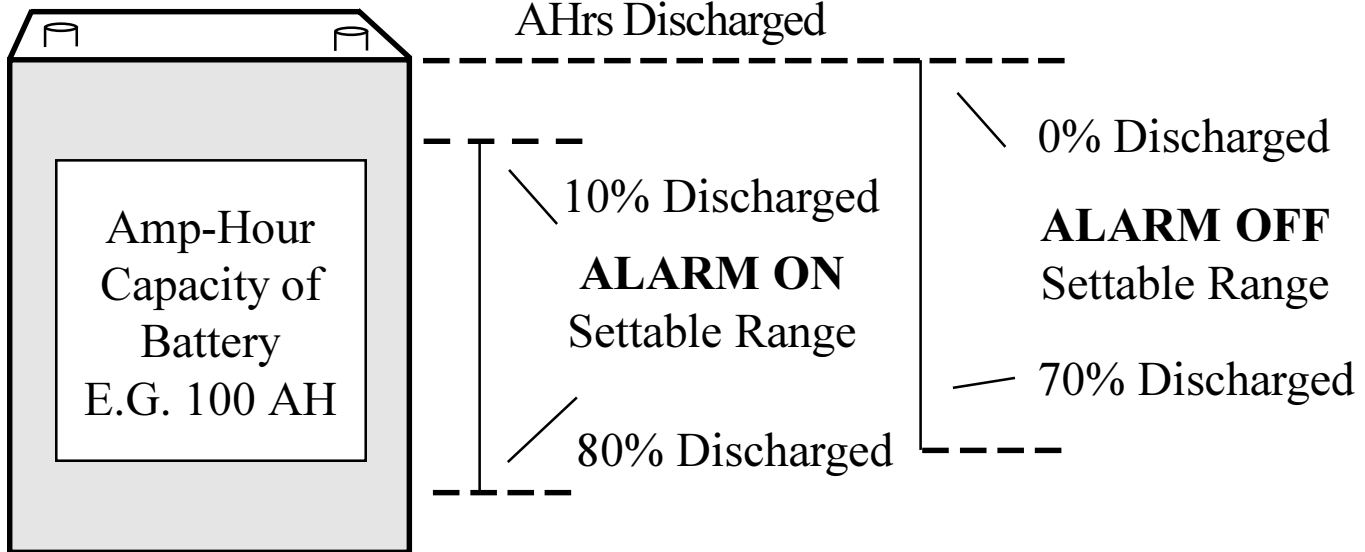

F10 LOW BATTERY ALARM OFF (RECHARGE) SET POINT

Once the Low Battery Alarm is activated, recharging the battery to this point turns the alarm OFF. This recharged point must always be at least 10% higher than Low Battery Line closure point.

DEFAULT: 70% RANGE: 0%-70% STEP: 5%

F11 LOW BATTERY ALARM ON SET POINT

Sets when the Low Battery Alarm goes ON point based on percent of Amp-hours discharged. F-11 is displayed in percent: i.e. 10 is 10% discharged. F-11 may set anywhere in its range but at least 10% below the **F10 Low Battery Alarm OFF Set Point** set point.

DEFAULT: 80% RANGE: 10%-80% STEP: 5%

NOTE: The Low Battery Alarm ON and OFF points operate on rate compensated (Peukert) Amp hours consumed. Once the alarm is activated, the battery must be charged until **Alarm OFF Set Point** is reached to turn the alarm off.

F12 LOW VOLTAGE ALARM THRESHOLD

F-12 sets the Voltage below which the Low Battery Alarm is activated. But the voltage must remain below this set point for a full 15 seconds before the Low Battery Alarm goes ON. Dropping below the Low Voltage Alarm Threshold for less than a full 15 seconds will not activate the Alarm.

If low voltage activates the Alarm while the battery is *above* the **Alarm OFF (Amp-hour) Set Point**, the alarm goes OFF as soon as voltage remains *above* the low voltage threshold for 15 seconds. If the battery is *below* the **Alarm OFF (Amp-hour) Set Point** when low voltages turns the Alarm ON, the alarm stays on until the battery is recharged to *above* the **Alarm OFF (Amp-hour) Set Point**.

RANGE: 5.0 - 40V (0 - 50V Scaling) STEP: 0.1V Default 10.5V

RANGE: 5.0 - 80V (0 -100V Scaling) STEP: 0.1V Default 10.5V

RANGE: 50 - 400V (0 -500V Scaling) STEP: 1.0V Default 105V

THINGS TO REMEMBER:

- 1) The Low Battery Alarm may be activated by *either* a low Voltage **OR** a low Amp-hour condition.
- 2) There must be a 10% difference between the Low Battery Alarm ON set point and Low Battery Alarm OFF (Recharge) Set Point.
- 3) Because Low Battery Alarm ON may be triggered by rated compensated (Peukert) Amp-hours, you may see fewer Amp-hours removed in the numeric display than expected. The more rapidly you have discharged your battery, the more pronounced this variance will be.

Optional Alarm Switch

Special versions of Your Meter are available, for additional charge, which include a solid state Alarm Switch to ground via rear panel terminal strip Pin #7. This option is use in a variety of settings such as lift pump lock out on fork lifts, two wire generator start/stop, audible low battery alarms, and charge controllers. The additional circuitry of the switch may not be retrofitted to Your Meter in the field. It must be included at the time of manufacture.

The Low Battery Alarm Switch goes low to meter ground when the alarm is activated. In other words, a sinking FET switch to the meter's negative power lead is completed while the alarm is active. This lead is protected against polarity reversal so the "switch" connection has about 1 Ohm of resistance. This should be taken into account when sizing relays or designing logic interfaces. The maximum amount of current which may be controlled by this circuit is 150 mA (0.150A) at no more than 50V. Below are two typical applications for the optional Low Battery Alarm Switch:

RELAY DRIVER DIAGRAM

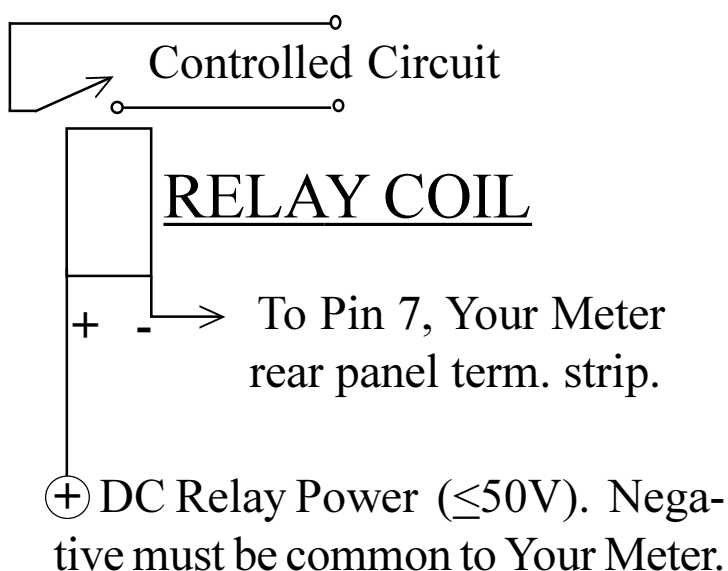

AUDIBLE ALARM

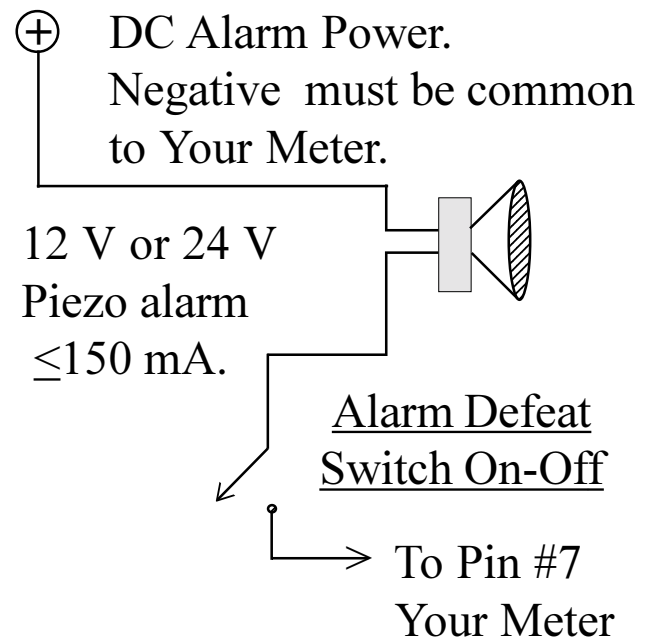

Peukert 's Equation

Peukert's Equation describes the effect of different discharge rates on battery capacity. As the discharge rate increases the available battery capacity decreases. The table and examples on the following page illustrate this effect and how to use the table to estimate the exponent "n". The tables on pages 34 & 35 have typical values of "n" for common batteries.

Making two discharge tests, one at a high discharge rate and one at a low rate, that bracket your normal range of operation, allows you to calculate an "n" that will describe this varying effect. Your Meter uses an "n" equal to 1.25 which is typical for many batteries.

At some low to moderate discharge rate, typically a battery's 20 hour rate, the logarithmic effect of Peukert's Equation is greatly reduced. The effect of discharge rates smaller than this is nearly linear. Battery manufacturer specifications of battery capacity in Amp-hours is typically given at the 20 hour rate. From this description, if a battery is discharged at this rate for the period of time called out, you will be able to remove the rated capacity.

The equation for Peukert's Capacity (C_p) is:

$$C_p = I^n t \quad \text{where} \quad n = \frac{\log t_2 - \log t_1}{\log I_1 - \log I_2}$$

By doing two discharge tests and knowing I_1 & I_2 (discharge current in Amps of the two tests), and t_1 & t_2 (time in hours for the two tests) you can calculate n (the Peukert coefficient). You will need a calculator that has a Log function to solve the equation above. See example on page 35. After you solve for your Peukert's coefficient you may enter it using Advanced Function F8.

Peukert's Equation

The table below may be used to understand the effect of high rates of discharge on available battery capacity. It may also be used to estimate the exponent "n" for a battery after a single discharge test. The table is based on a 100 Ahr battery but may be used for any capacity battery by using an appropriately scaled current. See the examples below:

PERCENTAGE OF AVAILABLE CAPACITY FROM A 100 Ahr BATTERY AT DIFFERENT DISCHARGE RATES USING DIFFERENT PEUKERT'S EXPONENTS

<u>EXPONENT</u>	<u>DISCHARGE RATE IN AMPS</u>													
	<u>n</u>	<u>5</u>	<u>10</u>	<u>16.7</u>	<u>25</u>	<u>50</u>	<u>75</u>	<u>100</u>	<u>150</u>	<u>200</u>	<u>250</u>	<u>300</u>	<u>400</u>	<u>500</u>
<u>1</u>	100	100	100	100	100	100	100	100	100	100	100	100	100	100
<u>1.1</u>	100	93	88	85	79	76	74	71	69	67	66	64	63	
<u>1.2</u>	100	87	78	72	63	58	55	51	48	46	44	42	40	
<u>1.25</u>	100	84	74	67	56	51	47	42	40	37	36	33	32	
<u>1.3</u>	100	81	69	62	50	44	41	36	33	31	30	27	25	
<u>1.4</u>	100	76	61	52	40	34	30	26	23	21	20	17	16	
<u>1.5</u>	100	71	55	45	32	26	22	18	16	14	13	11	10	

Example #1: Suppose you have a 200 Ahr battery. Now discharge at a 50 Amp rate until the battery reaches 1.75V per cell (10.5V for a 12V battery). This would be equivalent to a discharge rate of 25A for a 100 Ahr battery. If the battery delivered 67% (134Ahr) the appropriate Peukert's exponent would be 1.25.

Example #2: A 100 Ahr battery with a Peukert's exponent of 1.3 will deliver only 41% of its capacity when supplying a 100A load.

Peukert 's Exponent

Typical Values for Peukert's Exponent "n"

This table contains values for the exponent "n" for various batteries and manufactures. They are calculated from the 20 hour rating and the Reserve Minutes @ 25A as supplied by the manufacturer. They should be considered only a guide for selecting "n".

Prevailer & SeaGel Batteries

Model	Volts	Res. Min.	20 Hr. rating	"n"
8GGC	6	375	180	1.14
8GU1	12	43	43	1.20
8GU24	12	130	70	1.13
8GU27	12	167	86	1.12
8GU30H	12	188	95	1.12
84D	12	388	180	1.11
8G8D	12	500	225	1.10

Trojan Batteries

Model	Volts	Res. Min.	20 Hr. rating	"n"
T-105	6	447	225	1.24
T-125	6	488	235	1.19
T-145	6	530	244	1.14
J250	6	535	250	1.17
J305	6	660	305	1.21
L16	6	760	350	1.28
24TM	12	135	85	1.23
27TM	12	160	105	1.28
30XHS	12	225	130	1.27
SCS225	12	225	130	1.27
EV8D	12	450	216	1.17

Peukert 's Exponent

Surrette and Rolls Batteries

Model	Volts	Res. Min.	20 Hr. rating	"n"
EHG-208	6	345	208	1.42
EIG-225	6	350	225	1.54*
EIG-262	6	395	262	1.72*
24/90	12	165	90	1.16
27/12M	12	190	112	1.23
30H/108	12	230	108	1.08
HT/4D	12	348	170	1.15
HT/8D	12	450	221	1.20

*Use Max allowed "n" of 1.50

Example of using Reserve Minutes @ 25 Amps and the 20 hour rate to calculate "n".

First convert Reserve Minutes to hours, then find the discharge current at for the 20 hour rating. Finally use a calculator to solve the arithmetic.

Trojan T-105:

Reserve Minutes = 447 min @ 25 Amps.

$$t_1 = 447 \text{ min} = 447/60 = 7.45 \text{ hrs}$$

$$I_1 = 25 \text{ Amps}$$

20 Hour rating = 225 Ahr

$$t_2 = 20 \text{ hours}$$

$$I_2 = 225 \text{ Amp-hours}/20 \text{ hours} = 11.25 \text{ Amps}$$

$$n = \frac{\log t_2 - \log t_1}{\log I_1 - \log I_2} = \frac{\log 20 - \log 7.45}{\log 25 - \log 11.25} = \frac{1.301 - 0.872}{1.398 - 1.051} = 1.24$$

Troubleshooting

Condition	Suggestion
No lights or display	Check Power Connections Reset meter (Page 32)
No keyboard response	Check Lock is not invoked Reset meter (Page 32)
Time Remaining Not Accurate	Check Battery Capacity (Page 21) Check Temperature Coef. (Page 35) Check Peukert Exponent (Page 26)
Digital Display Dim	Clean front panel photo-sensor (Between A and Ah lights)
Current Polarity Reversed	Current Shunt leads reversed. (Page 13)
Intermittent Operation	Corrosion or loose wires. Loosen and reconnect all rear panel connections. Check voltage sense and shunt wiring at battery location.
Accumulates Negative Amp-hour reading	Charge Parameters not met. Check Charged Parameter values, Has 100% of Kwhrs been returned? Charging Current is not passing through shunt. (Pages 13,22,23, & Function F04)

CECO warrants that Your Meter will measure Voltage, Amperage, and Amp-Hours within the published specifications. The Time remaining and LED bar graph functions are complicated and require appropriate user set up and are therefore beyond the control of CECO and are not covered by warranty. Similarly installation wiring and specific applications are beyond our control and are not covered by warranty. See Page 51.

Options & Versions

User installable **OPTIONS** available include:

Prescalers: Extend the voltage range covered by Your Meter to either 0-100V (CECO Part #900087) or 0-500V (CECO Part #900086).

Temperature Sensor: Reports battery temperature in Degrees Celcius (CECO Part #900105)

All other options must be installed at the time Your Meter is manufactured as additional circuitry is involved.

Special order **VERSIONS** of Your Meter

RS-232 (9600,8,N,1 ASCII computer port)

Alarm Switch Switch closure when Low Battery Alarm is active.

RS-232 + Alarm Switch (Both options above)

If you need to log data from an RS-232 equipped version of Your Meter, ask your dealer about Cruising Equipment Company's **Memory Module**. This is a 1 MB data logger which captures data once per second, once each 10 seconds, once per minute or once each 10 minutes. It's ideal for proof of performance logging for PV and wind systems. If you are developing electric vehicles, ask about the **Memory Module w/GPS**. In addition to data logging, this specialized data logger uses the Global Positioning System to record precise time and vehicle speed.

High Voltage Prescaler

CAUTION!

1. Installation of the Prescaler Option involves work with potentially fatal voltages. **NEVER** work alone: Have at least one person present who can render assistance and CPR in the event of an accident. If you have any doubt about your qualifications to work on a high voltage system, ***DON'T DO IT!***
2. When working with any DC system, even so-called ungrounded ("*floating*") systems with no *planned* chassis connection, disconnect the negative battery terminal first.

**Use a Prescaler if system voltage EVER exceeds 50V!
Then set voltage scaling with F13 (See Page 50).**

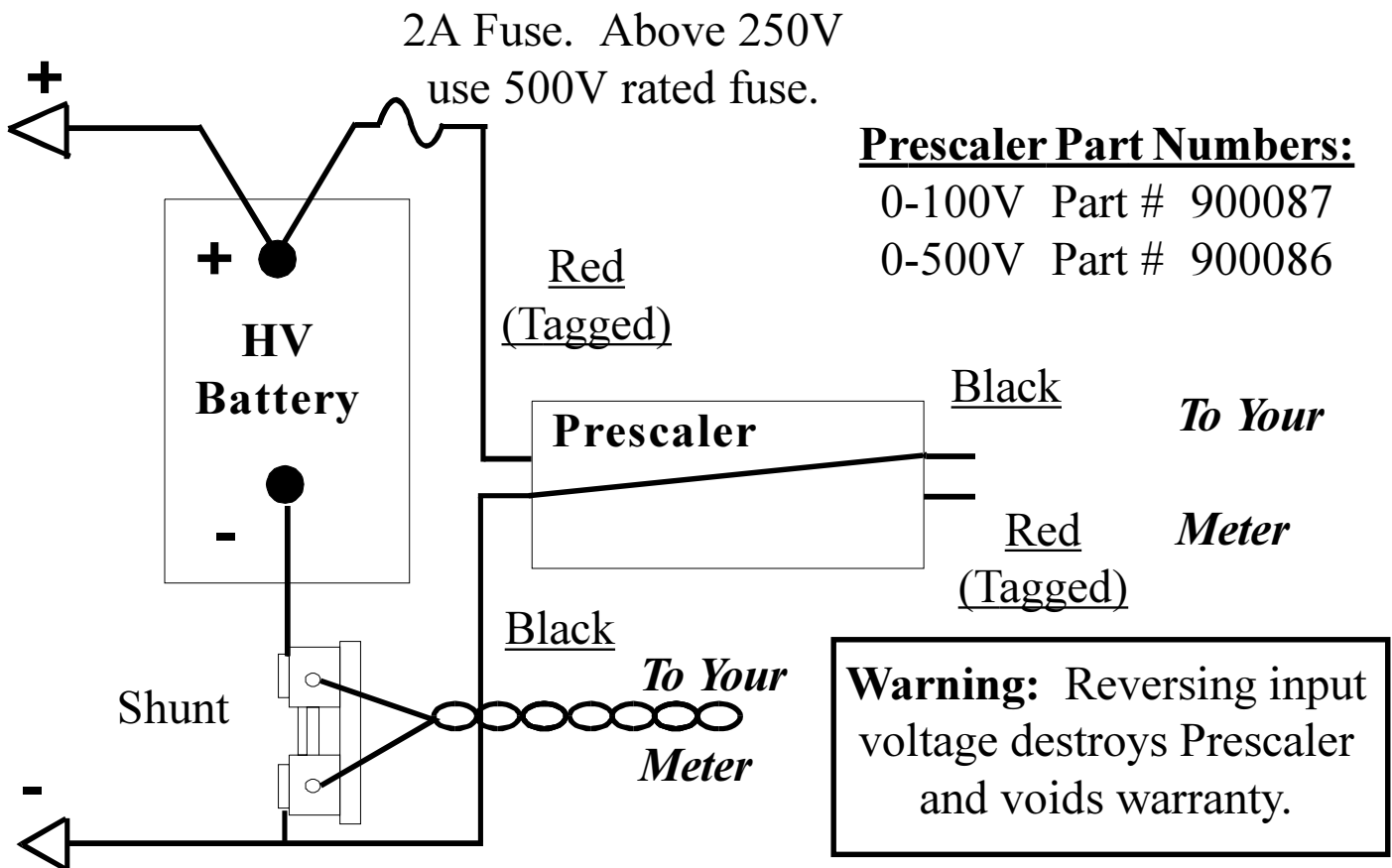

Note: Black wires are common within Prescaler. 45

Electric Vehicles (EV's)

Your Meter is the ideal energy meter for EV instrumentation. It not only provides Volts, Amps, Amp-hours and Time Remaining, it adds two important bonuses: Kilowatt-hours and optional serial computer output.

If you design or work with electric vehicles or battery powered equipment of any type, you should realize that Kilowatt-hours are a more accurate measure of energy used than are Amp-hours. Here's why:

The term "Amp-hour" defines current (Amps) multiplied by time (hours). Amp-hours is one way to state battery capacity. Amp-hours is *not* a measure of energy consumed by a vehicle. Energy is defined as:

Energy in Watt-hours = Voltage x Amperage x time.

Consider two examples: First, assume we have a 120 Volt battery that supplies a 100 Amp load for 1 hour. At the end of one hour, 12,000 Watt-hours (12.00 Kwhrs) will have been consumed. In the same period of time, 100 Amp-hours will be used.

But now suppose we have a 240 Volt battery supplying a 100 Amp load for one hour. What happens to the math? Well, 24,000 Watt-hours (24.00 Kwhrs) of power have been consumed. The Amp-hours consumed is the same as the first example, 100 Amp-hours, but *twice* the energy has been consumed!

That's why electric vehicle efficiency is judged on Kilowatt-hours. A Kilowatt-hour is a 1,000 watt load for a period of one hour. You buy kilowatt-hours from the power company (to keep the lights on in your home) at a typical cost of \$0.05 to \$0.15 per KWh. By comparing the cost of Kilowatt-hours from the electric company with Kilowatt-hour consumption of an electric vehicle, you can accurately judge EV operating costs.

Refer to Owner's Manual for instructions on use of the KWh display.

EV Installations

The negative of Your Meter's power supply must be common to the negative of the battery (motive pack) which you are measuring. This may pose difficulty if your electric vehicle uses an "unbonded" or "floating" [no connection to the chassis] motive pack and a "bonded" [connected to the chassis] accessory battery. **In these instances, the use of a DC-DC converter, or a separate battery with a common negative with the motive battery is required.** This device provides power for Your Meter without electrically connecting the motive battery negative to the chassis. The diagram shown is for a DC-DC converter typically supplied by Cruising Equipment Company (Part # 313075). If you use a different DC-DC converter, the pin-out may be different:

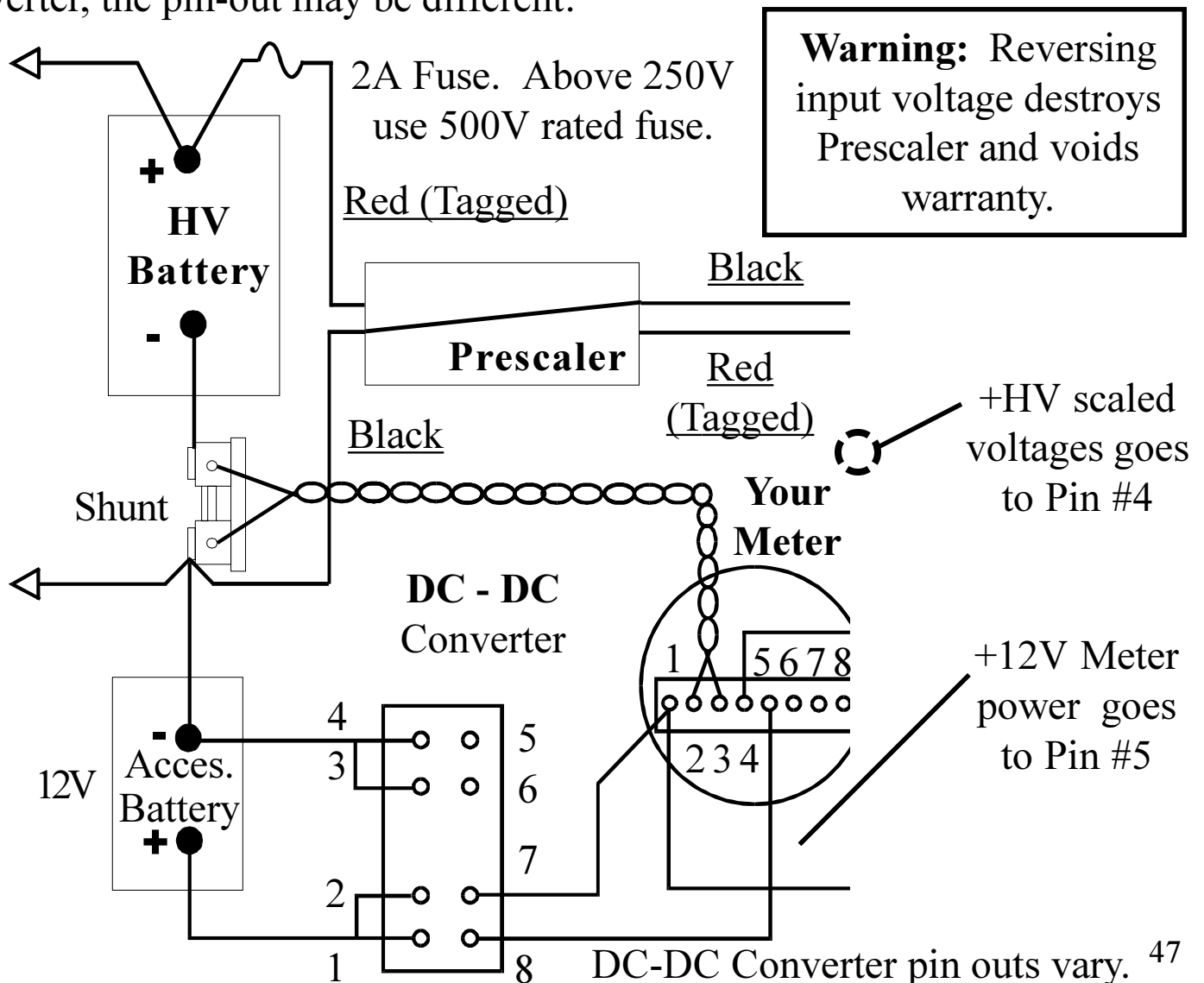

Lift Truck Installations

Installation of Your Meter in Lift Trucks, which have the motive pack bonded to the chassis and also have a 12V accessory battery bonded to the chassis, may use the diagram below for proper wiring of the appropriate Prescaler. The 0-100V Prescaler is used where system voltage does not exceed 100V at any time including during onboard charging. In any other instance, a 500V Prescaler must be used. If possible, install separate Anderson(SMH) connector so pack can be charged in truck if batteries are not changed. This way, battery cycles will be counted.

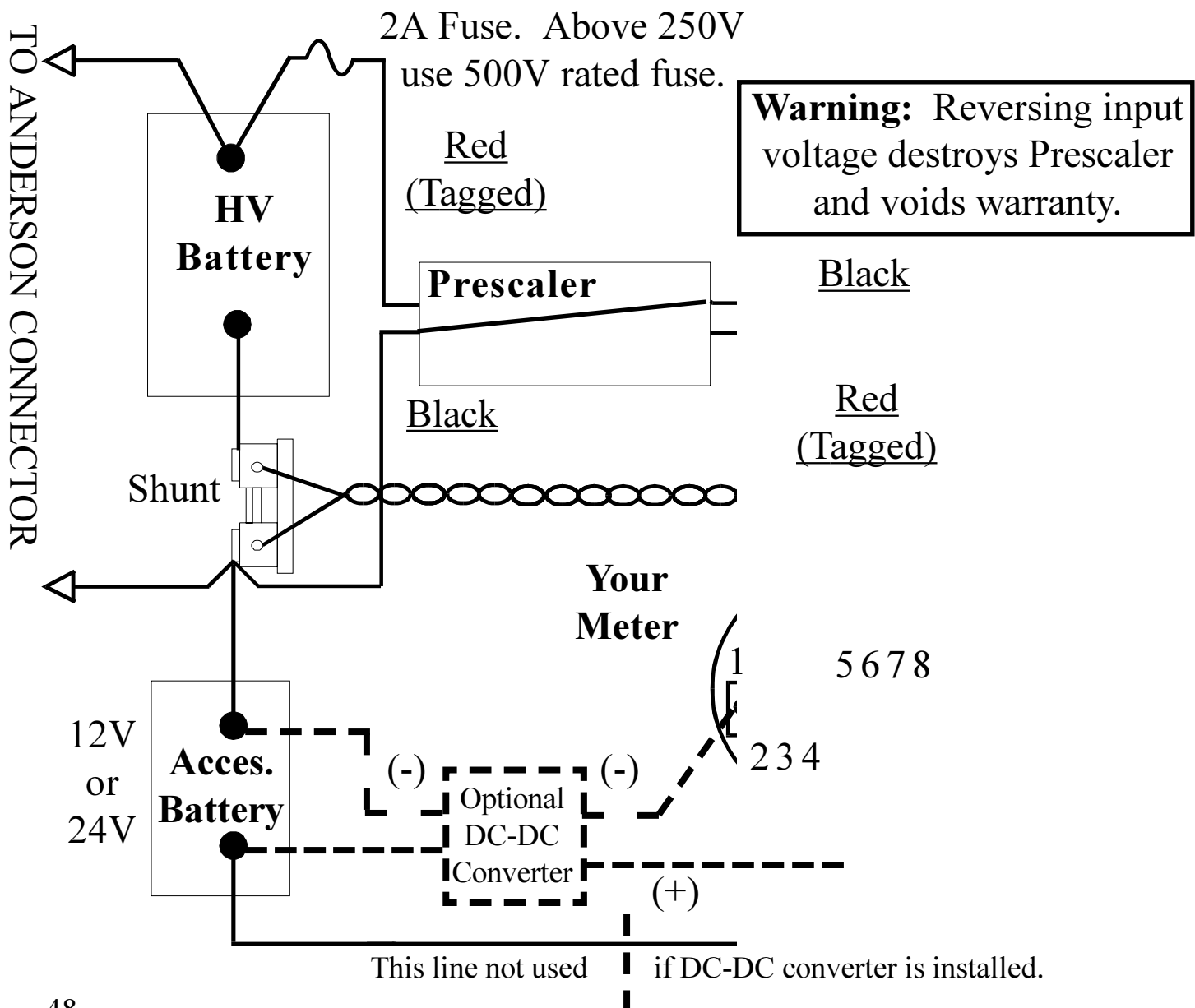

(optional) Serial Port, RS-232

Your Meter may be equipped to transmit serial communications data to a personal computer or a data logging device, such as our Memory Module. When equipped with the optional RS-232 port, Your Meter will transmit a data message once a second. The structure of this data is as follows:

Data Rate: 9600 **Data Bits:** 8
Stop Bits: 1 **Parity Bits:** None
Word: ASCII Characters, comma delimited

Output Format:

Time, KWhrs, Amps, Volts, Ahrs, Peukert Ahrs, Peukert Amps, Time remaining, Bar Graph state, Temperature (degrees C.)

Time is elapsed seconds since last Amp-hour reset. Kilowatt-hours are signed + or -, Amp-Hours are signed + or -, Amps are signed + or -, Volts are positive, time remaining is in hours or tenths of hours.

Peukert Amps and Peukert Amp-hours are compensated for Peukert's equation. These numbers are primarily intended for our development and troubleshooting. Please do not attempt to interpret these numbers.

The Bar Graph state is indicated by the following integers:

1<20%, 2<40%, 3<60%, 4<80%, 5<100%, 6 = Full (Charged Params met)

If the Low Battery Output is activated, the Bar Graph state is indicated as:

A<20%, B<40%, C<60%, D<80%, E<100%, F = Full (Charged Params met)

Pin Out:

The serial connection is via the DB-9 connector on the rear deck of Your Meter. See additional notes on Page 11. The pin connections are as follows:

Pin 2 Receive Data line
Pin 3 Transmit Data line
Pin 5 Ground This is connected to battery pack (-).

The shell of the DB-9 is NOT grounded.

High Voltage Notes

HOW TO SET VOLTAGE SCALING WHEN USING A HIGH VOLTAGE PRESCALER

F13 SET VOLTAGE SCALING

Sets proper voltage scaling when used with an external Voltage Prescaler. **NOTE:** If you use a Prescaler, you need to change the **Charged Voltage** to an appropriate value for your application. See Pages 21 & 22 of **Owner's Manual** - "*Charged Parameters*".

DEFAULT: 0= 0-50V. Options: 1= 0-100V, 2= 0-500V

IF YOU USE MOTIVE BATTERIES TO POWER YOUR METER:

If the HV battery is "tapped" to provide meter power, it is recommended that a 24V tap, not a 12V tap, be used. The reason for this is that under heavy acceleration under low battery conditions, voltage may fall to levels low enough to cause the meter display to turn off momentarily. Under extreme circumstances, historical data may also be lost.

AVOID DATA LINE SHOCK HAZARD:

If you have a floating ground system and Your Meter is equipped with the RS-232 Serial Computer Port option and is being used to record data into a laptop computer, we strongly recommend use of an optical isolator such as Omega Cat #268 to eliminate danger of a HV short to ground or personal shock hazard. Use caution in connecting wires to the DB-9 on the rear of Your Meter as Pin #5 is connected directly to motive battery (-).

EC Declaration of Conformity

CE

Manufacturer: Cruising Equipment Co.

Address: Cruising Equipment Co.
5245 Shilshole Ave. NW
Seattle, WA 98107
U.S.A.

Herewith declares that: E-Meter Battery State of Charge Meters

Models:	E-Meter	Link 10
	Battery Monitor	DCM-1000
	Energy Manager	Checkmate
	Batt-Meter	

**Is in conformity with the provision of the EEC Directive
EMC 89/336/EEC and amendments 92/31/EEC, 93/68/EEC.
The following harmonized standards have been applied:**

**EN 50081-1: 1992
EN 50082-1: 1992**

Limited Warranty

The purchase of Your Meter includes one 15 minute phone call. You must have a serial number to access the service department. Subsequent calls will be billed at \$1.00/minute with a \$15.00 minimum. Please have your Mastercard or Visa ready. This policy is strictly enforced in an effort to keep the product cost as low as possible. Our experience is that more than 90% of problems are installation or operation related that could have been solved by reading this manual. You may also contact your dealer or the OEM whose name appears on the front of Your Meter for support.

Cruising Equipment Co. (CECO) warrants to the original purchaser only for 18 months from the date of purchase that Your Meter (hereafter Meter) will be in good working order when properly installed and operated as described in this Manual.

If your Meter fails to perform or becomes defective under normal use and service, CECO, will, without charge, at CECO's place of business, within a reasonable time after delivery, repair, or at CECO's option, replace with a new or factory reconditioned part any part found defective.

In order to avail yourself of the warranty you must:

1. Contact: & Obtain warranty authorization from CECO (Address below.)
2. Ship the Meter, charges prepaid, with proof of purchase within 18 months of its sale to you.

This warranty is void and will not apply if:

1. Your Meter has been modified, repaired, or opened without written authorization from CECO:
2. The identification markings on your Meter have been altered or removed:
3. Your Meter has been damaged through abuse, neglect, exposure to sea spray, lighting strikes, high voltage, accident, voltage reversal.
4. Your Meter was not installed and operated according to the owner's manual or was operated under conditions more severe than those specified in the owners manual.

THE FOREGOING WARRANTY IS IN LIEU OF ALL OTHER WARRANTIES, INCLUDING THE WARRANTIES OF FITNESS FOR A PARTICULAR PURPOSE AND MERCHANTABILITY, EXPRESS OR IMPLIED, AND OF ALL OBLIGATIONS OR LIABILITIES ON THE PART OF CECO FOR DAMAGES, INCLUDING, BUT NOT LIMITED TO LOSS OF TIME, INCONVENIENCE, COMMERCIAL LOSS OR CONSEQUENTIAL DAMAGES, WHICH MAY ARISE OUT OF, OR IN CONNECTION WITH, THE USE OR PERFORMANCE OF THE METER.

Some states do not allow the exclusion or limitation of incidental or consequential damages, and some states do not allow limitations on how long and implied warranty lasts, so if the law of that state applies, the above limitation or exclusion may not apply to you. This warranty gives you specific legal rights and you may also have others which vary from state to state.

Cruising Equipment Company
5245 Shilshole Ave. N.W. Seattle, WA 98107 USA
Telephone: (206) 782-8100 Fax: (206) 782-4336

RS-232 Warning

When using an RS-232 equipped version of Your Meter in an electric vehicle which has a floating motive battery negative, remember that Pin #5 of the DB-9 connector coming out of the back of Your Meter is connected to the motive battery negative.

This normally causes no problem when used with our Memory Modules or with laptop computers. However, if you plug the DB-9 RS-232 output into a computer with a metal chassis then motive battery negative will be connected to the chassis of the computer.

THIS EXPOSED BATTERY NEGATIVE MAY BE HAZARDOUS, AND POSSIBLY FATAL IF YOU HAVE A HIGH SIDE MOTIVE PACK FAULT.

We strongly recommend that when using a Memory Module or computer to log data, you minimize the hazard by installing an RS-232 Opto-Isolation Module. One such module is available through OMEGA ELECTRONICS (Model 268 cost \$126). Omega's phone number is 1-800-848-4271.

Please note you will also have to purchase DB-25 to DB-9 adapters as Model 268 uses DB-25 connectors. Be certain you purchase straight through adapters, not the null modem type!

NOTES

NOTES

The Battery Monitor that's *EASY TO INSTALL!*

If you can drill 1 hole...

Connect 5 wires....

Follow a few simple instructions....

You can have the
Ultimate Battery Monitor!

Features

Splashproof!

Multicolor Bar Graph Display

Time Remaining Display

Amp-Hours consumed

Digital Volt & Amp Meter

LED shows active display

Custom Setup Capability

Lockable Front Panel Display

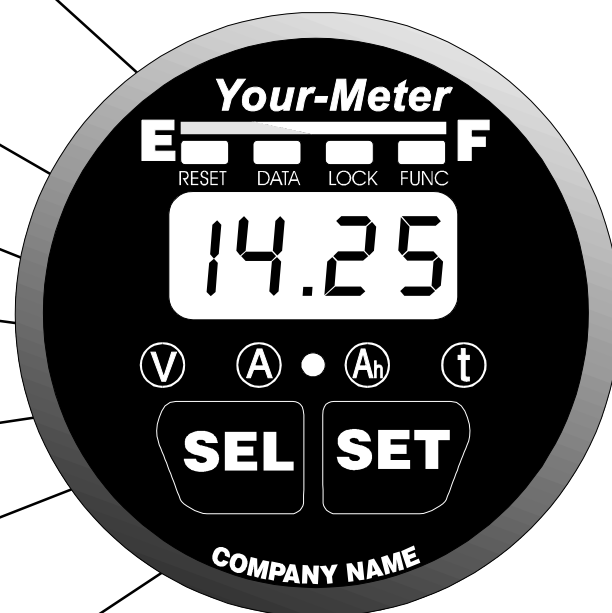

Mfg. by: Cruising Equipment Company
5245 Shilshole Ave. NW, Seattle, WA 98107 U.S.A. Phone: (206) 782-8100 Fax: (206) 782-4336
Visit our web site at: <http://www.cruisingequip.com>

Change Log

4/10/97 - Page references corrected, under light display on bottom of page 20.

- ref to page 34 changed to 30
- ref to page 32 changed to 28
- ref to page 32 changed to 29
- ref to page 32 changed to 28

-ref page 25 line 1 temp. sesnor change to temp. sensor.

4/16/97

- F08 scrunch on P-32 corrected
- Set low battery alarm page reference corrected to 35-38 on page 33
- Operation of Function Test of Lights F17 changed page 34

6/3/97 Changed battery capacity page 21 set up to read 20-40 amp hour range instead of 10-40 range - as meter doesn't do 10 amp-hour capacity!

12/30-97 Moved master einstall5b.pm6 to Source Safe on Server. Revised and reinstalled graphics. Cleaned up many drawings where things had moved slightly. Added "patented" in lieu of patent pending notices. Revised prescaler drawing to conform to color coding and noted (tagged) on dwgs. Improved back cover layout.

Software History

Software Enhancement Rev. E 1.5

Your Meter now includes the following additional functions:

F02 - ENHANCED SLEEP MODES

DEFAULT: ON **Range: ON, OFF, AUTOMATIC**

When the Sleep Mode is ON, Your Meter's numeric display turns off after 10 minutes in order to reduce power consumption. Pressing either SET or SEL buttons returns the numeric display to operation.

When the Sleep Mode is OFF, the numeric display stays on at all times. In the AUTOMATIC sleep mode (displayed as *AUT*), the numerics are on whenever charging or discharging exceeds 1 Amp. When the rate of charge or discharge remains less than 1 Amp for 10 minutes, the numeric display is turned off to conserve power. When asleep, pressing either SET or SEL reactivates the numeric display. The numeric display automatically wakes up when the rate of charge or discharge exceeds 1 Amp. The Automatic Sleep Mode is ideal for Electric Vehicles.

TIME REMAINING DISPLAY

DEFAULT: 001 **Range: 000, 001, 002, 003, P**

When *P* is selected, an averaged Time Remaining number is not displayed. Instead, Your Meter reports *rate compensated* Percent of (declared) Battery Capacity Remaining. A full battery is displayed as 100*P* and the display decrements during discharge to 00*P*.

If you have selected a discharge floor other than 100%, the Percent of Battery Capacity Remaining is referenced to the selected discharge floor and uses the instantaneous (not averaged) rate of discharge.

This function is useful on Electric Vehicles where Time Remaining numbers are of little value. NOTE: This display shows the rate compensated capacity percentage which drives the Bar Graph.

Software Addendum

Software Enhancement

This version of Your Meter includes special software.

F18 - SMALL BATTERY SENSING

DEFAULT: OFF Range: OFF, ON

When this function is OFF, the meter operates as described elsewhere in this manual. When this function is ON, the amp-hour capacity range allows capacities as low as 2 amp-hours to be declared. When ON, capacity may be set from 2 - 200 amp-hours, and small capacity increments are allowed as follows:

From 2 - 40 amp-hours, 1 Ahr capacity increments are permitted.

Above 40 (to 198 amp-hours), 2 Ahr capacity increments are permitted.

